



MDL Solutions VK **TECHNICAL** catalogue

2015_01

VK15





VK15

Trench Heater with Natural Convection type VK15

Trench heating from Verano has been designed considering their primary usage in spacious interiors of domestic and light commercial buildings that may have many glassing façades. Due to this heating emitters from Verano will suit perfectly to luxury apartments, office blocks, utility buildings, car showrooms, shopping malls or even church buildings – whilst everywhere, where building occupants may consider keeping optimal temperature being well composed to interior design esthetics and discreetness.

Trench heating is considered as a significant part of any modern heating system. Heating emitter that is assembled in a

floor based, trench casing and covered with an elegant aluminum, wood or stainless steel grille would compose with a room in a based possible manner, as by being discrete-nearly invisible, it does not interfere with space or specific room character requirements.

In most case scenarios of interior design, it is recommended to place trench heating along the glazed façades and wind-screens or French Windows keeping their length the same as façade/windscreen or French Window. Trench heating could be also placed along core walls and building corners.

Trench heating being used along facade would create an air curtain that will act as a natural barrier that separates cold and hot air, thus would restrict so called cold air draught at the low level of a room, would minimize heat losses whilst would increase the entire heating system efficiency.

Trench heating from Verano are available as a straight line trench casing and coils, but also we offer on demand curved and angle version that will suit any atypical interior design and will harmonise with the modern but specific building architecture.

Benefits of trench heating

ENERGY EFFICIENCY

Exceptional energy savings is primary achieved by very low effective water capacity, perfect heating resistance and low thermal inertia.

Trench heating from Verano may work very well with every single kind and type of thermal control what also may be consider as one of critical factor for reducing heating energy bills.



FUNCTIONALITY

Trench heating distributes heating in perfect and discrete manner inside spacious and elegant interiors that having usually large glass façades. The only visible element of trench heating is an elegant grille that is composed into the floor that covers trench and coil elements.

Easy access through taking off a grille would enable easy access for cleaning or maintenance of a trench heating.

COMFORT

Trench heating are the ones that among many types of heating emitters would react in the quickest way for any changes of any thermal requirements in a room. This quick adaptation capacity allows to avoid any room overheating.

Trench heating that are placed along the outskirts of a building would create a natural air curtain that may separate warm and cold air and prevents 'floating' cold air at the low, floor base level.

Using trench heating allows to eliminate of the moisture condensation from the surface of glass façades.

Heating any interior by using a natural convection allows to provide even temperature distribution and a natural circulation of air in any room.

DURABILITY

There are high quality materials being used for designing copper aluminum coil, that also warrants corrosion resistance but also protection against low quality of water from the boiler.

Due to using a raw steel with hot dip zmc coating our heating emitters are usually more corrosion resistant.



The equipment of Verano heater

STANDARD equipment:

- trench (casing) made of hot-dip galvanized steel sheet with zinc magnesium coating, powder painted in black RAL 9005,
- copper and aluminium heat exchanger with air vent,
- dividers for trench heaters $H \geq 140$ mm,
- water connection $2 \times IT \frac{3}{4}$ " (internal thread),
- fixing anchors,
- leveling brackets $H \geq 250$ mm,
- connection space cover.

ADDITIONAL equipment:

- trench (casing) painted in any RAL colour,
- frame around the heater casing, L or F type made of natural aluminum, powder coated in RAL, anodized or can be done as wood imitation,
- aesthetic grille made of aluminum (natural, anodized or powder painted in any RAL color), natural wood (oak, ash, beech, merbau, jatoba) or stainless steel,
- Installation cover to protect against damage during transport and installation,

Construction of Verano heater

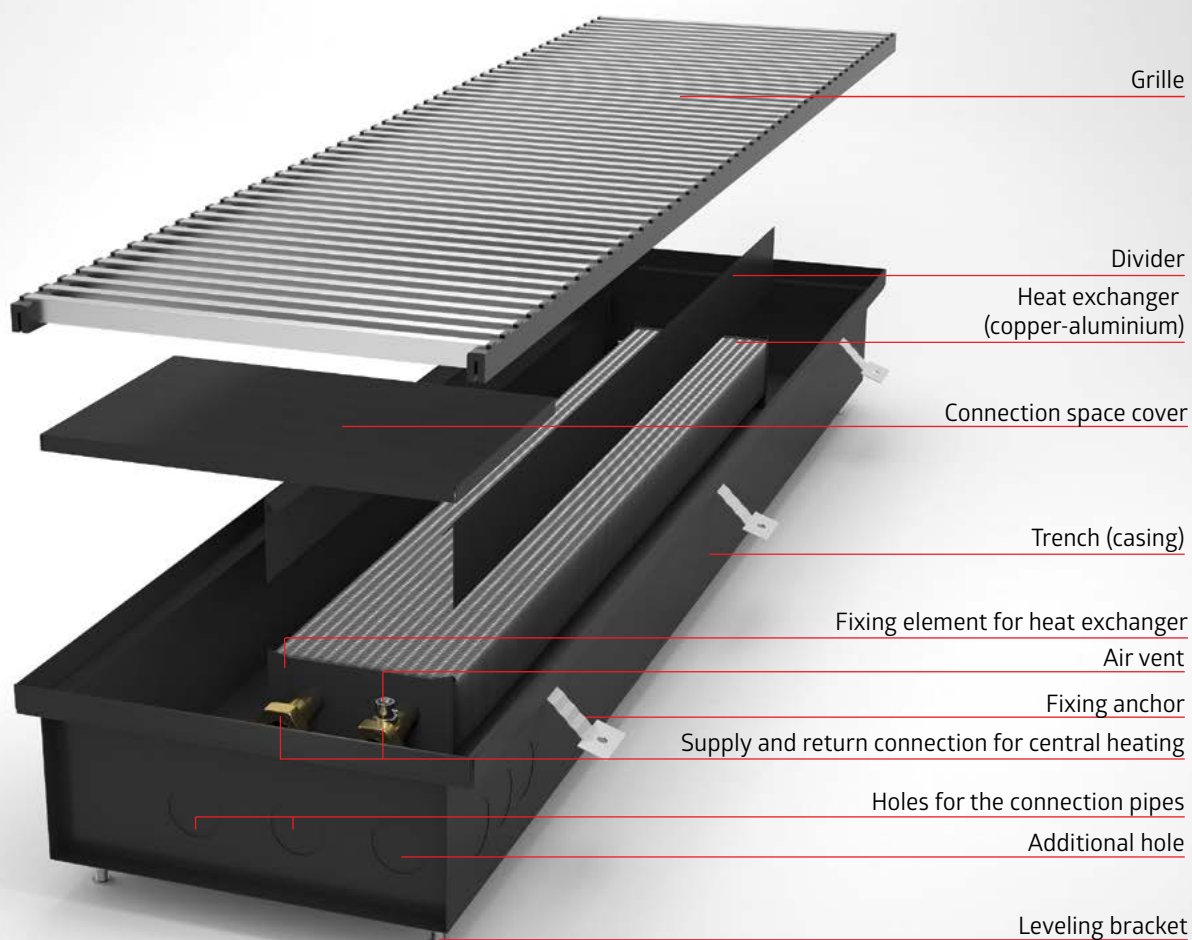

VK15





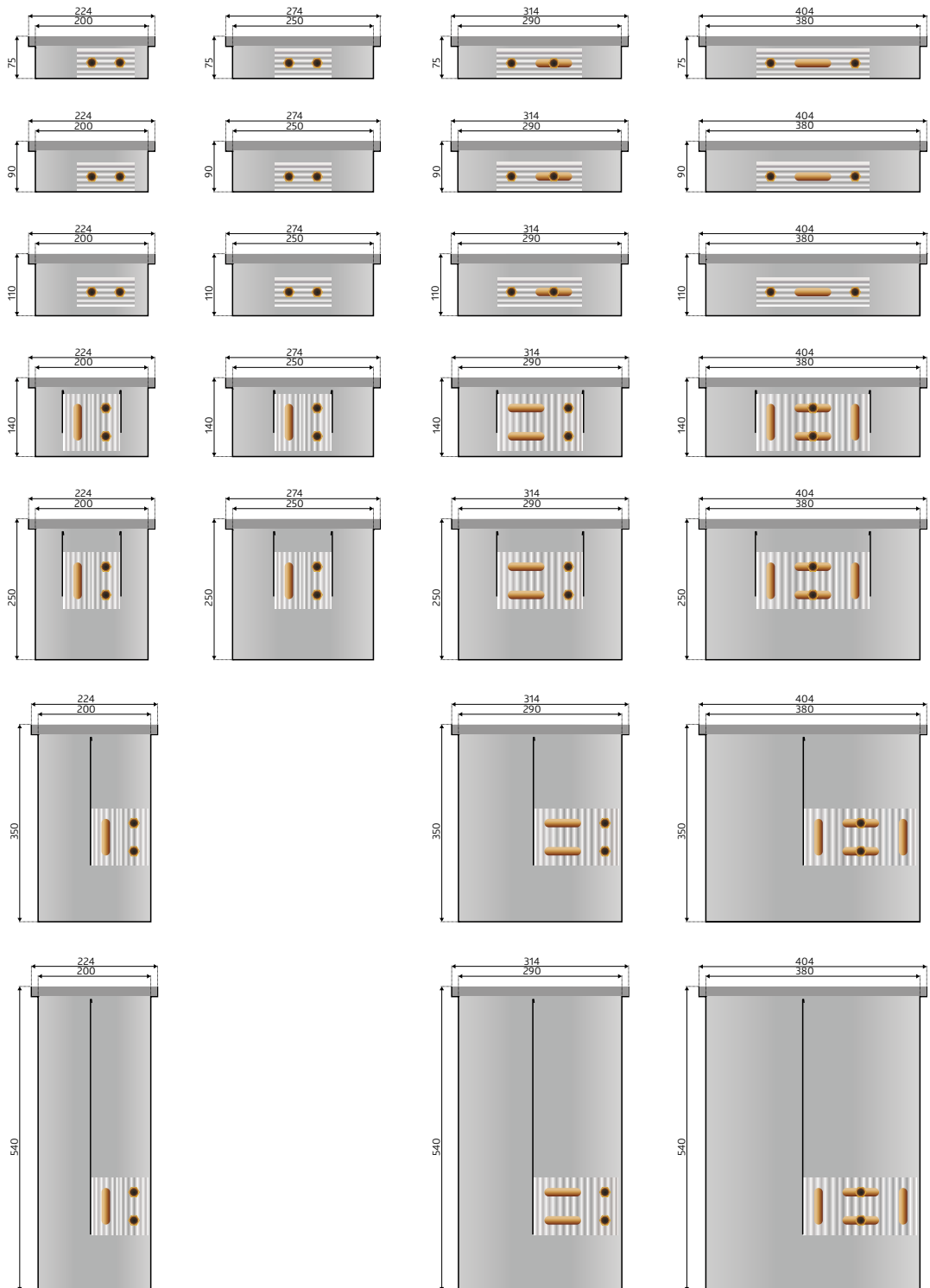









Dimensions

Trench height (H) 75, 90, 110, 140, 250, 350, 540 mm
 Trench width (W) 200, 250, 290, 380 mm
 Trench length (L) 800 - 4000 mm
Order code VK15-H/W/L-fin type
 Heaters are also available with a non standard/custom lengths (NS).





Control devices

Straight thermostatic valve typ VDN 215 Siemens	Valve diameter 15 DN	
Angular thermostatic valve type Siemens VEN 215	Valve diameter 15 DN	
Straight return valve type Siemens ADN 15	Valve diameter 15 DN	
Angular return valve type Siemens AEN 15	Valve diameter 15 DN	
Straight thermostatic valve type Schlösser 601200004	Valve diameter 15 DN	
Angular thermostatic valve type Schlösser 601200005	Valve diameter 15 DN	
Straight return valve type Schlösser 601300004	Valve diameter 15 DN	
Angular return valve type Schlösser 601300002	Valve diameter 15 DN	
Thermostatic valve with remote control setpoint type Siemens RTN 81	Remote setting element with 2m long capilar	
Thermal servo-motor type Siemens STA 23 or STA 23/00	Supply voltage 230 V AC, STA23 with 1 m connection cable, 2-position control, STA23/00 need a separate cable ASY23L...	
Cabel – type Siemens ASY23L...	Connecting cable to STA 23/00 length 2m, 3m, 5m, 2-position control	
Room temperature controller type Siemens RDD 100	Operating modes: Comfort, Economy, Protection. 2-position control ON / OFF for heating. Power Supply 230 V AC (RDD100) or battery 3 V DC (RDD100.1)	
Room temperature controller type Siemens RDE 100	Operating modes: Normal mode and Energy saving. 2-position control with ON / OFF for heating. Weekly program and manual control; Power Supply 230 V AC (RDE10) or battery 3 V DC (RDE10.1)	
Room thermostat type Siemens RAA21	Digital input thermostat (on / off) with changeover contact for automatic room temperature control and other applica- tions in heating and air conditioning systems; Designed for use in small and medium-sized installations.	

Control options for the trench heater type VK15

Option 1:

Thermostatic valve
Return valve
Thermostatic head with remote control
set-point

Option 2:

Thermostatic valve
Return valve
Electro-Thermal servo-motor
Room temperature controller

Control devices
The control options of Verano Trench Heater with Natural Convection type VK15

Connection of the trench heaters/heat exchangers to the central heating installation can be made by means of widely used thermostatic valves and special thermostatic heads. Thermostatic valve is mounted on the heating element in the trench, while the thermostatic head on the wall of the heated room. The valve and the head are connected by capillary inside the protective pipe in the wall. The thermostatic head should be mounted in easily accessible places 1,2-1,6m above the floor level. There are two reasons why the head must not be installed on the valve in the trench: firstly, such a location of the head will inhibit obtaining proper temperature regulation (inside the casing is higher temperature); secondly, it will hinder access to the head.



When electric regulation is required, a method includes the use of room temperature controller along with electro-thermal servomotor and valves. The thermostat measure the temperature in the room by sensors and maintains the temperature previously set. When the temperature in the room falls below the value set on the thermostat, the thermal servomotor will open the valve and make the water flow. Room temperature controller should be located in such a place to be able to measure as precise as possible without the impact of sun radiation or any heat or cold sources. The installation should be mounted approximately 1.5 m over the floor.

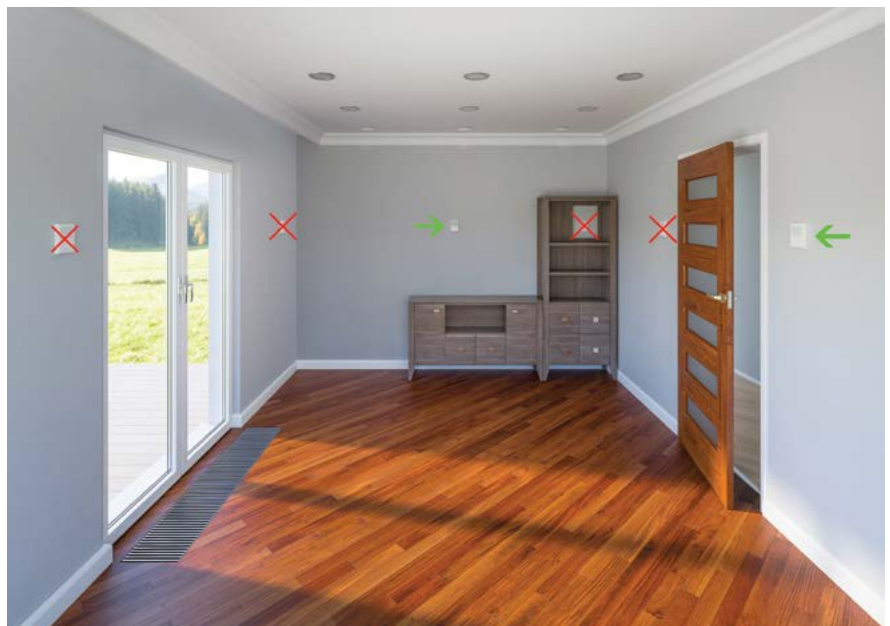

Installation manual

In order to settle down the trench casing, you need to know precisely width of all layers of a floor. Due to esthetic and usability aspects any frame of the trench should be leveled up or down in order to harmonise with the floor level. The frame of trench is integrated within and should be located firmly (must not be exposed into any bending conditions). Trench casing should be assembled firmly in order to put flat the bottom of a trench casing into the concrete floor, because any grille frame is not resistant against holding the weight of it.

Holding brackets that keeps the coil firmly during any transport, are adjusted to the trench casing with screws. Before any trench heating is assembled, please unscrew those holding brackets. When the trench heating unit is being assembled, please lock the screws.

Prepared floor gap for trench has to be firm and made in accordance to building regulations. It is necessary to insulate trench against any moisture, similar to the entire building but also using thermal insulation made from e.g. Styrofoam of 20 ÷ 50 mm thickness. This is due to reducing any heat losses. One should bear in mind that the side walls of the trench are not designed with enough firmness to hold a large pressure, therefore it is recommended to fill in such specific spaces between trench sides and casing sides with low pressure mounting foam (such spaces must not be filled in with any concrete material).

Day to day usage

There is an elegant grille covering coil from the top of a trench as a trench finish. Any grilles made from wood are raw (not painted) only. In order having a grille well protected, you should stain and paint a wood. Aluminum grilles could be made of natural aluminum, that is powder coated in any RAL colour, or anodized, or wooden alike painted. Stainless steel version of a grille is available only linear bar.

Every single grille has been designed for covering c.a. 30% of a trench top surface. If any more of a top of trench surface would be covered, this should result less output produced by trench heating. Using any trench heating during heat season, you

When preparing a trench in depth and width, you need to consider adding c.a. 20mm to width and length and c.a. 30mm to depth as of mounting clearance. Considering the necessity of keeping a technical catalog outputs precisely it is recommended providing any assembly and installation works in according to manuals being attached.

In trench heating of the following depths: 75, 90, 110, 140 i 250 mm a coil is situated at the middle of trench casing. However in trench heating of the following depths: 350, 540 mm it is situated closer to the side of trench casing. Trench heater that have one side air inlet should be assembled in a way that coil is placed on the room side.

Compartment bars should be placed on the brackets, once the trench heater is fully connected to the water installation. Compartment bars should separate a part of trench casing where the cold air is being directed from the part of trench casing where warm heated by coil is being taken out to the room.

should not cover it by any furniture or by rug/carpet. It is quite important matter keeping the trench clean inside it.

Grilles are step and rub-away resistant when concerning any little foot traffic. Due to this it is not recommended putting trench heating in places where a large foot traffic areas are expected.

Trench heaters from Verano Convector should be carefully cleaned at least once per annum – the best is doing it before heat season. Heating emitters should be clean from any dust both trench casing and a coil.



Grille e.g. aluminium

Aluminium frame e.g. type F

Flooring
Silencing layer

Concrete

Hard polystyrene

Low expansion foam

Fixing anchor

Leveling bracket

- ▲ An example of assembly a shallow trench heater
- ▼ An example of assembly a deep trench heater

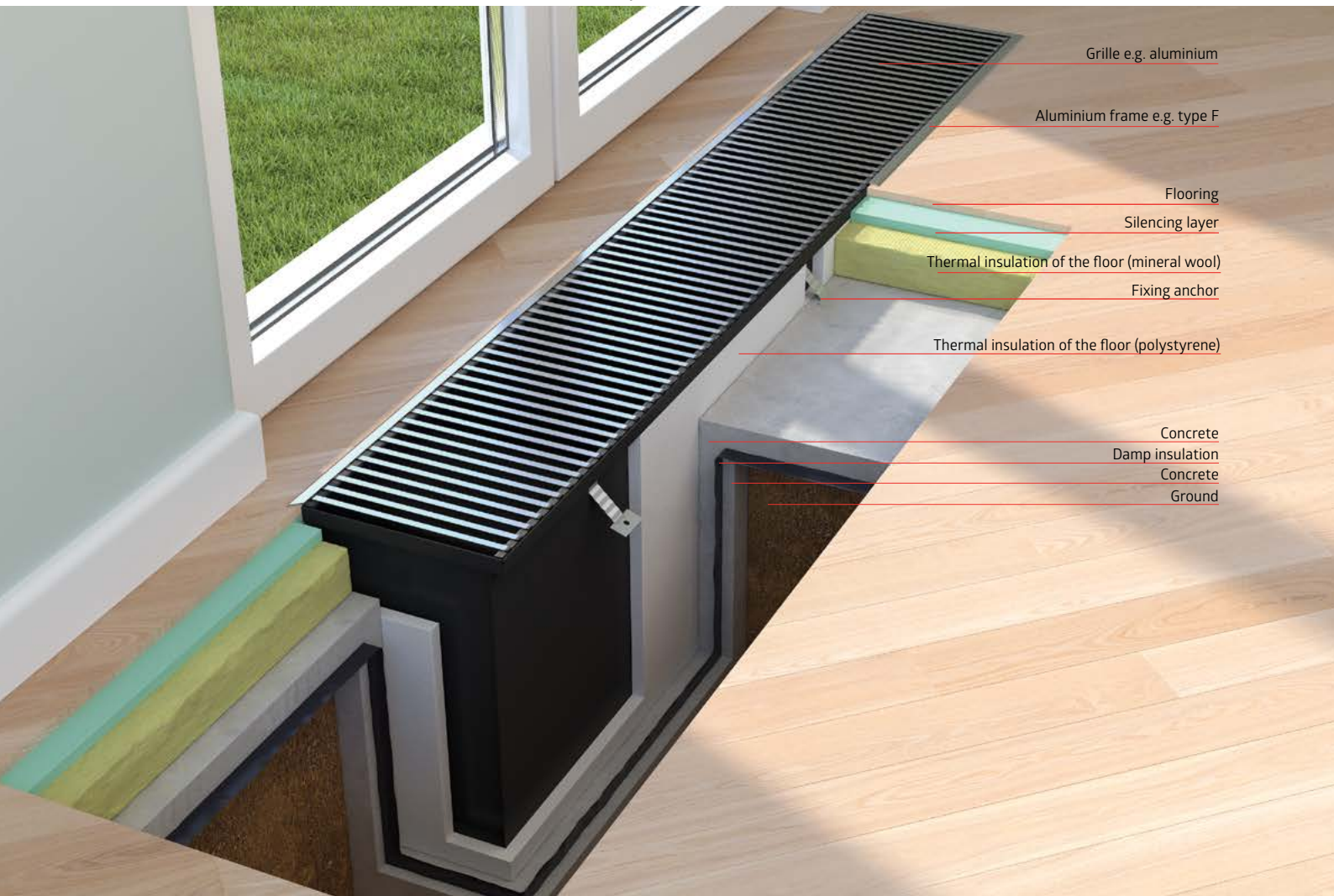

Grille e.g. aluminium

Aluminium frame e.g. type F

Flooring
Silencing layer

Thermal insulation of the floor (mineral wool)

Fixing anchor

Thermal insulation of the floor (polystyrene)

Concrete

Damp insulation

Concrete

Ground

VK15

75 mm height

VK15-7.5/20/L-12

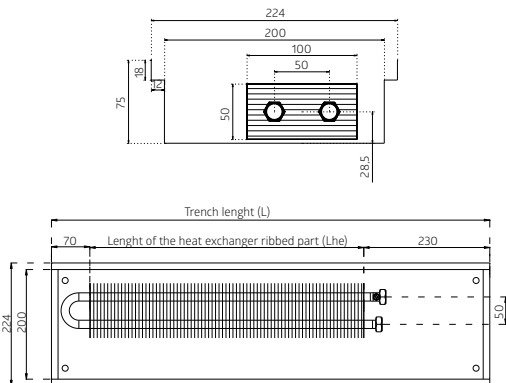

DIMENSIONS	UNIT [mm]
Trench height (H)	75
Trench width (W)	200
Grille width (Wg)	224
Trench length (L)	800 ÷ 4000
Lenght of the heat exchanger ribbed part (Lhe)	L - 300
Fin type	12
CONNECTIONS	TYPE
Connection threads	IT 3/4" one-sided
Side connection to be choosen	(Standard Right - P, optional Left - L)
ACCESORIES	TYPE
Grille H=18 mm	roll-up/linear/modular
Aluminium frame	type L or F
Assembly cover	on request

Please remember:

Order code for heaters type VK15:

VK15-H/W/L-fin type

where:

H - Trench height [mm]
W - Trench width [mm]
L - Trench Length [mm]

Ts/Tr °C	L [mm]										
	800	1000	1300	1600	1900	2200	2500	2800	3200	3600	4000
90/70	145	204	291	378	465	552	640	727	843	960	1076
75/65	114	159	227	295	363	431	499	568	658	749	840
70/55	91	127	182	237	291	346	401	455	528	601	674
55/45	57	79	113	147	181	215	249	283	328	374	419
50/40	44	62	89	115	142	168	195	221	257	292	328

Heat outputs [W] according to EN 442 for the room air temperature Ti= 20°C

VK15-7.5/25/L-12

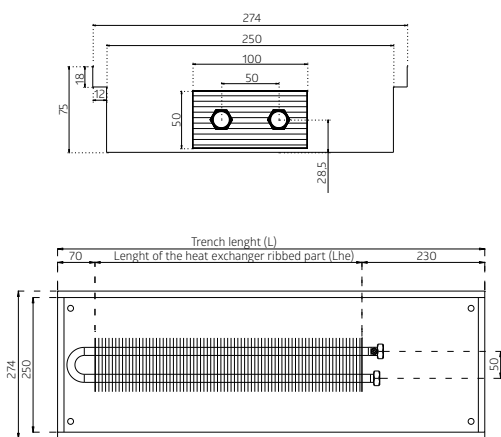

DIMENSIONS	UNIT [mm]
Trench height (H)	75
Trench width (W)	250
Grille width (Wg)	274
Trench length (L)	800 ÷ 4000
Lenght of the heat exchanger ribbed part (Lhe)	L - 300
Fin type	12
CONNECTIONS	TYPE
Connection threads	IT 3/4" one-sided
Side connection to be choosen	(Standard Right - P, optional Left - L)
ACCESORIES	TYPE
Grille H=18 mm	roll-up/linear/modular
Aluminium frame	type L or F
Assembly cover	on request

Ts/Tr °C	L [mm]										
	800	1000	1300	1600	1900	2200	2500	2800	3200	3600	4000
90/70	189	265	378	491	605	718	831	945	1096	1247	1398
75/65	148	207	295	384	472	561	649	738	856	974	1092
70/55	118	166	237	308	379	450	520	591	686	781	875
55/45	74	103	147	191	236	280	324	368	427	486	545
50/40	58	81	115	150	184	219	253	288	334	380	426

Heat outputs [W] according to EN 442 for the room air temperature Ti= 20°C

75 mm height

VK15

DIMENSIONS	UNIT [mm]
Trench height (H)	75
Trench width (W)	290
Grille width (Wg)	314
Trench length (L)	800 ÷ 4000
Length of the heat exchanger ribbed part (Lhe)	L - 300
Fin type	13
CONNECTIONS	TYPE
Connection threads	IT 3/4" one-sided
Side connection to be choosen	(Standard Right - P, optional Left - L)
ACCESORIES	TYPE
Grille H=18 mm	roll-up/linear/modular
Aluminium frame	type L or F
Assembly cover	on request

VK15-7.5/29/L-13

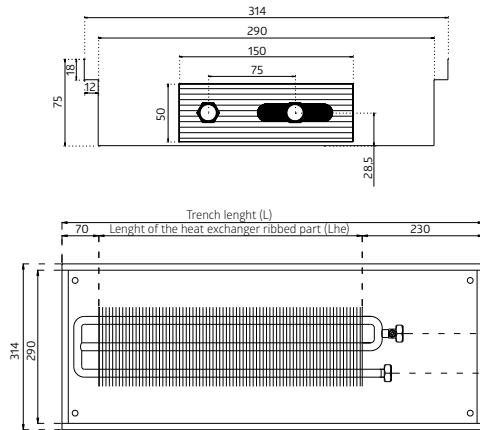

Ts/Tr °C	L [mm]										
	800	1000	1300	1600	1900	2200	2500	2800	3200	3600	4000
90/70	245	343	491	638	785	932	1079	1227	1423	1619	1815
75/65	192	268	383	498	613	728	843	958	1111	1264	1417
70/55	154	215	307	399	491	584	676	768	891	1014	1137
55/45	96	134	191	248	306	363	420	478	554	631	707
50/40	75	105	149	194	239	284	329	373	433	493	553

Please remember:

Order code for heaters type VK15:

VK15-H/W/L-fin type

where:

H - Trench height [mm]
W - Trench width [mm]
L - Trench Length [mm]

Heat outputs [W] according to EN 442 for the room air temperature $T_i = 20^\circ\text{C}$

DIMENSIONS	UNIT [mm]
Trench height (H)	75
Trench width (W)	380
Grille width (Wg)	404
Trench length (L)	800 ÷ 4000
Length of the heat exchanger ribbed part (Lhe)	L - 300
Fin type	14
CONNECTIONS	TYPE
Connection threads	IT 3/4" one-sided
Side connection to be choosen	(Standard Right - P, optional Left - L)
ACCESORIES	TYPE
Grille H=18 mm	roll-up/linear/modular
Aluminium frame	type L or F
Assembly cover	on request

VK15-7.5/38/L-14

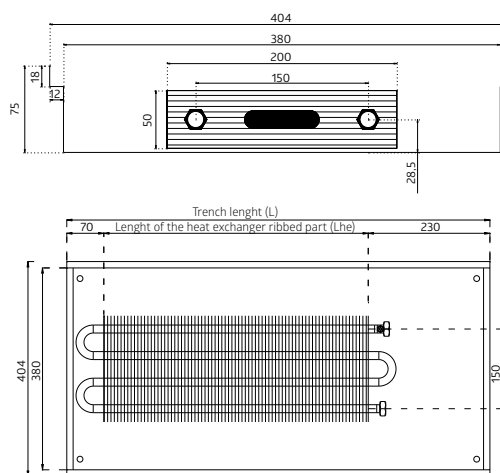

Ts/Tr °C	L [mm]										
	800	1000	1300	1600	1900	2200	2500	2800	3200	3600	4000
90/70	354	496	708	921	1133	1346	1558	1771	2054	2338	2621
75/65	277	387	553	719	885	1051	1217	1383	1604	1825	2046
70/55	222	310	444	577	710	843	976	1109	1286	1464	1641
55/45	138	193	276	359	442	524	607	690	800	911	1021
50/40	108	151	216	280	345	410	474	539	625	712	798

Heat outputs [W] according to EN 442 for the room air temperature $T_i = 20^\circ\text{C}$

VK15

90 mm height

VK15-9/20/L-12

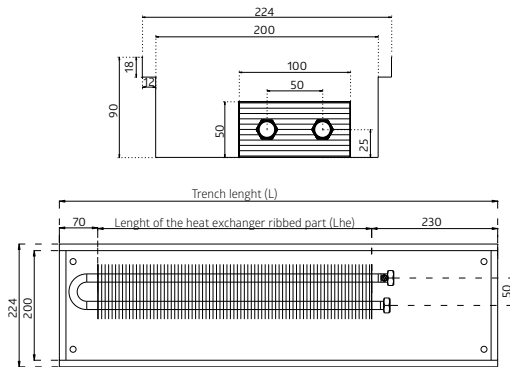

DIMENSIONS	UNIT [mm]
Trench height (H)	90
Trench width (W)	200
Grille width (Wg)	224
Trench length (L)	800 ÷ 4000
Lenght of the heat exchanger ribbed part (Lhe)	L - 300
Fin type	12
CONNECTIONS	TYPE
Connection threads	IT 3/4" one-sided
Side connection to be choosen	(Standard Right - P, optional Left - L)
ACCESORIES	TYPE
Grille H=18 mm	roll-up/linear/modular
Aluminium frame	type L or F
Assembly cover	on request

Please remember:

Order code for heaters type VK15:

VK15-H/W/L-fin type

where:

H - Trench height [mm]
W - Trench width [mm]
L - Trench Length [mm]

Ts/Tr °C	L [mm]										
	800	1000	1300	1600	1900	2200	2500	2800	3200	3600	4000
90/70	172	240	343	446	549	652	755	858	996	1133	1270
75/65	134	188	268	348	429	509	590	670	777	884	992
70/55	107	150	215	279	344	408	473	537	623	709	795
55/45	67	94	134	174	214	254	294	334	388	441	495
50/40	52	73	105	136	167	199	230	261	303	345	387

Heat outputs [W] according to EN 442 for the room air temperature Ti= 20°C

VK15-9/25/L-12

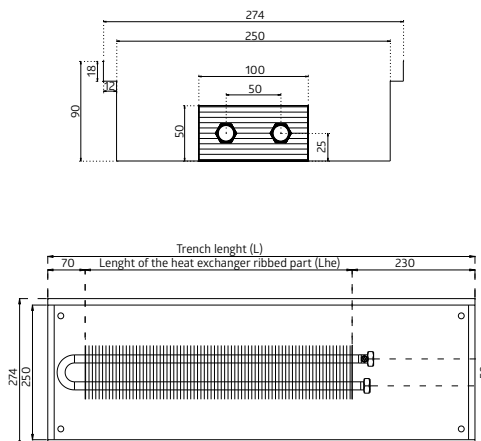

DIMENSIONS	UNIT [mm]
Trench height (H)	90
Trench width (W)	250
Grille width (Wg)	274
Trench length (L)	800 ÷ 4000
Lenght of the heat exchanger ribbed part (Lhe)	L - 300
Fin type	12
CONNECTIONS	TYPE
Connection threads	IT 3/4" one-sided
Side connection to be choosen	(Standard Right - P, optional Left - L)
ACCESORIES	TYPE
Grille H=18 mm	roll-up/linear/modular
Aluminium frame	type L or F
Assembly cover	on request

Ts/Tr °C	L [mm]										
	800	1000	1300	1600	1900	2200	2500	2800	3200	3600	4000
90/70	222	310	443	576	709	842	975	1108	1285	1463	1640
75/65	173	242	346	450	554	657	761	865	1003	1142	1280
70/55	139	194	277	361	444	527	610	694	805	916	1027
55/45	86	121	173	224	276	328	380	432	501	570	639
50/40	67	94	135	175	216	256	297	337	391	445	499

Heat outputs [W] according to EN 442 for the room air temperature Ti= 20°C

90 mm height

VK15

DIMENSIONS	UNIT [mm]
Trench height (H)	90
Trench width (W)	290
Grille width (Wg)	314
Trench length (L)	800 ÷ 4000
Length of the heat exchanger ribbed part (Lhe)	L - 300
Fin type	13
CONNECTIONS	TYPE
Connection threads	IT 3/4" one-sided
Side connection to be chosen	(Standard Right - P, optional Left - L)
ACCESORIES	TYPE
Grille H=18 mm	roll-up/linear/modular
Aluminium frame	type L or F
Assembly cover	on request

VK15-9/29/L-13

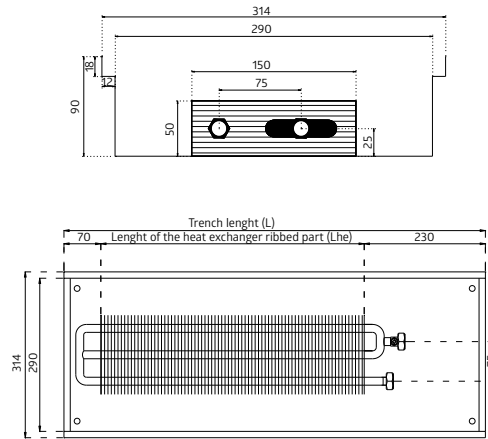

Ts/Tr °C	L [mm]										
	800	1000	1300	1600	1900	2200	2500	2800	3200	3600	4000
90/70	289	404	578	751	924	1098	1271	1444	1675	1907	2138
75/65	226	316	451	586	722	857	992	1128	1308	1488	1669
70/55	181	253	362	470	579	687	796	904	1049	1194	1338
55/45	113	158	225	293	360	428	495	563	653	743	833
50/40	88	123	176	229	281	334	387	440	510	580	651

Please remember:

Order code for heaters type VK15:

VK15-H/W/L-fin type

where:

H - Trench height [mm]
W - Trench width [mm]
L - Trench Length [mm]

Heat outputs [W] according to EN 442 for the room air temperature $T_i = 20^\circ\text{C}$

DIMENSIONS	UNIT [mm]
Trench height (H)	90
Trench width (W)	380
Grille width (Wg)	404
Trench length (L)	800 ÷ 4000
Length of the heat exchanger ribbed part (Lhe)	L - 300
Fin type	14
CONNECTIONS	TYPE
Connection threads	IT 3/4" one-sided
Side connection to be chosen	(Standard Right - P, optional Left - L)
ACCESORIES	TYPE
Grille H=18 mm	roll-up/linear/modular
Aluminium frame	type L or F
Assembly cover	on request

VK15-9/38/L-14

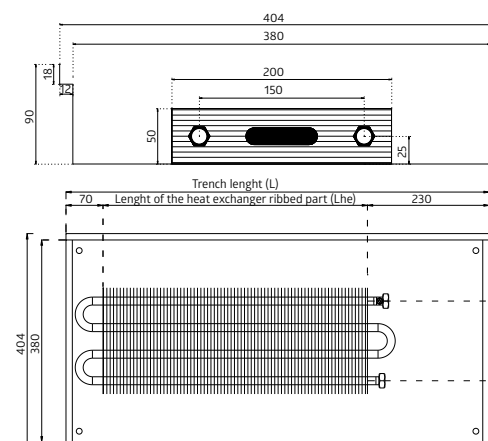

Ts/Tr °C	L [mm]										
	800	1000	1300	1600	1900	2200	2500	2800	3200	3600	4000
90/70	416	583	833	1082	1332	1582	1832	2082	2415	2748	3081
75/65	325	455	650	845	1040	1235	1430	1625	1885	2145	2405
70/55	261	365	521	678	834	990	1147	1303	1512	1720	1929
55/45	162	227	324	422	519	616	714	811	941	1070	1200
50/40	127	177	254	330	406	482	558	634	735	837	938

Heat outputs [W] according to EN 442 for the room air temperature $T_i = 20^\circ\text{C}$

VK15

110 mm height

VK15-11/20/L-12

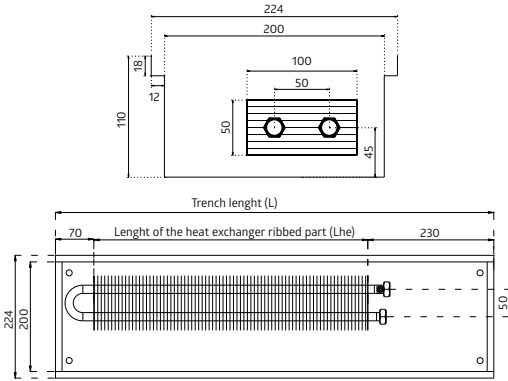

DIMENSIONS	UNIT [mm]
Trench height (H)	110
Trench width (W)	200
Grille width (Wg)	224
Trench length (L)	800 ÷ 4000
Lenght of the heat exchanger ribbed part (Lhe)	L - 300
Fin type	12
CONNECTIONS	TYPE
Connection threads	IT 3/4" one-sided
Side connection to be choosen	(Standard Right - P, optional Left - L)
ACCESORIES	TYPE
Grille H=18 mm	roll-up/linear/modular
Aluminium frame	type L or F
Assembly cover	on request

Please remember:

Order code for heaters type VK15:

VK15-H/W/L-fin type

where:

- H - Trench height [mm]
- W - Trench width [mm]
- L - Trench Length [mm]

Ts/Tr °C	L [mm]										
	800	1000	1300	1600	1900	2200	2500	2800	3200	3600	4000
90/70	198	277	396	515	633	752	871	990	1148	1306	1465
75/65	155	216	309	402	494	587	680	773	896	1020	1143
70/55	124	173	248	322	397	471	545	620	719	818	917
55/45	77	108	154	200	247	293	339	385	447	509	571
50/40	60	84	121	157	193	229	265	301	349	398	446

Heat outputs [W] according to EN 442 for the room air temperature Ti= 20°C

VK15-11/25/L-12

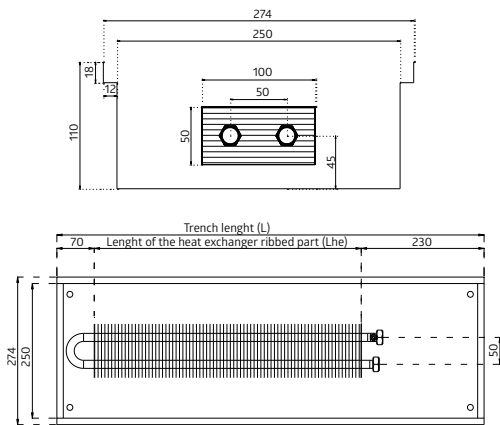

DIMENSIONS	UNIT [mm]
Trench height (H)	110
Trench width (W)	250
Grille width (Wg)	274
Trench length (L)	800 ÷ 4000
Lenght of the heat exchanger ribbed part (Lhe)	L - 300
Fin type	12
CONNECTIONS	TYPE
Connection threads	IT 3/4" one-sided
Side connection to be choosen	(Standard Right - P, optional Left - L)
ACCESORIES	TYPE
Grille H=18 mm	roll-up/linear/modular
Aluminium frame	type L or F
Assembly cover	on request

Ts/Tr °C	L [mm]										
	800	1000	1300	1600	1900	2200	2500	2800	3200	3600	4000
90/70	262	367	524	681	838	995	1153	1310	1519	1729	1939
75/65	205	286	409	532	654	777	900	1023	1186	1350	1513
70/55	164	230	328	426	525	623	722	820	951	1082	1214
55/45	102	143	204	265	327	388	449	510	592	674	755
50/40	80	112	160	207	255	303	351	399	463	526	590

Heat outputs [W] according to EN 442 for the room air temperature Ti= 20°C

110 mm height

VK15

VK15-11/29/L-13

DIMENSIONS	UNIT [mm]
Trench height (H)	110
Trench width (W)	290
Grille width (Wg)	314
Trench length (L)	800 ÷ 4000
Length of the heat exchanger ribbed part (Lhe)	L - 300
Fin type	13
CONNECTIONS	TYPE
Connection threads	IT 3/4" one-sided
Side connection to be chosen	(Standard Right - P, optional Left - L)
ACCESORIES	TYPE
Grille H=18 mm	roll-up/linear/modular
Aluminium frame	type L or F
Assembly cover	on request

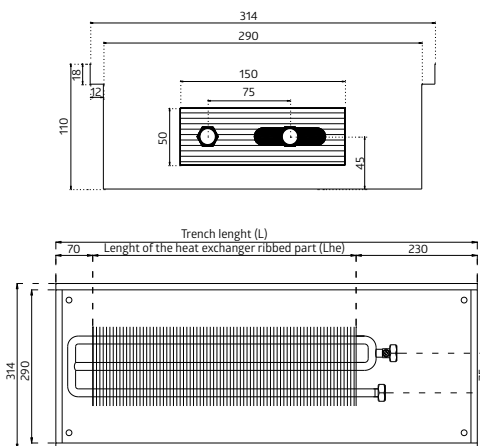

Ts/Tr °C	L [mm]										
	800	1000	1300	1600	1900	2200	2500	2800	3200	3600	4000
90/70	341	478	683	888	1092	1297	1502	1707	1980	2253	2526
75/65	267	373	533	693	853	1013	1173	1333	1546	1759	1972
70/55	214	299	427	556	684	812	940	1069	1240	1411	1582
55/45	133	186	266	346	426	505	585	665	771	878	984
50/40	104	146	208	270	333	395	457	520	603	686	769

Please remember:

Order code for heaters type VK15:

VK15-H/W/L-fin type

where:

H - Trench height [mm]

W - Trench width [mm]

L - Trench Length [mm]

Heat outputs [W] according to EN 442 for the room air temperature Ti= 20°C

DIMENSIONS	UNIT [mm]
Trench height (H)	110
Trench width (W)	380
Grille width (Wg)	404
Trench length (L)	800 ÷ 4000
Length of the heat exchanger ribbed part (Lhe)	L - 300
Fin type	14
CONNECTIONS	TYPE
Connection threads	IT 3/4" one-sided
Side connection to be chosen	(Standard Right - P, optional Left - L)
ACCESORIES	TYPE
Grille H=18 mm	roll-up/linear/modular
Aluminium frame	type L or F
Assembly cover	on request

VK15-11/38/L-14

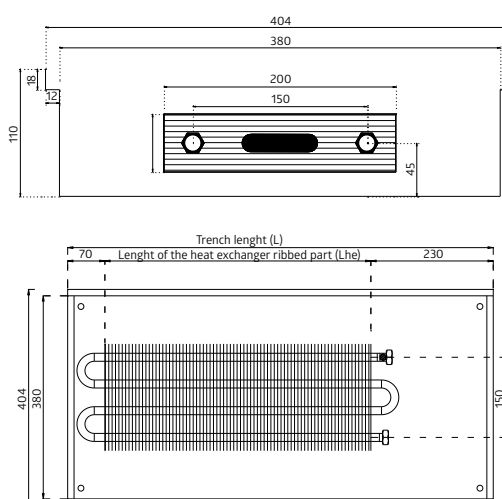

Ts/Tr °C	L [mm]										
	800	1000	1300	1600	1900	2200	2500	2800	3200	3600	4000
90/70	479	671	958	1246	1533	1821	2108	2395	2779	3162	3545
75/65	374	524	748	972	1197	1421	1646	1870	2169	2468	2768
70/55	300	420	600	780	960	1140	1320	1500	1740	1980	2220
55/45	187	261	373	485	597	709	821	933	1082	1232	1381
50/40	146	204	292	379	467	554	642	729	846	963	1079

Heat outputs [W] according to EN 442 for the room air temperature Ti= 20°C

VK15

140 mm height

VK15-14/20/L-22

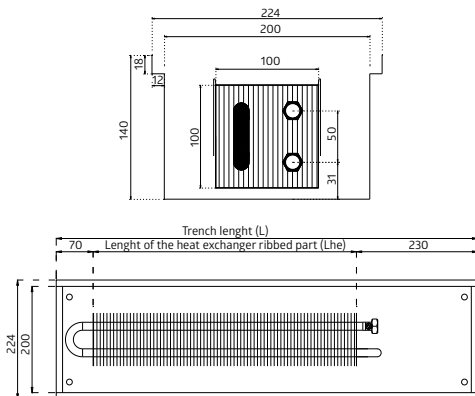

DIMENSIONS	UNIT [mm]
Trench height (H)	140
Trench width (W)	200
Grille width (Wg)	224
Trench length (L)	800 ÷ 4000
Lenght of the heat exchanger ribbed part (Lhe)	L - 300
Fin type	22
CONNECTIONS	TYPE
Connection threads	IT 3/4" one-sided
Side connection to be choosen	(Standard Right - P, optional Left - L)
ACCESORIES	TYPE
Grille H=18 mm	roll-up/linear/modular
Aluminium frame	type L or F
Assembly cover	on request

Please remember:

Order code for heaters type VK15:

VK15-H/W/L-fin type

where:

H - Trench height [mm]
W - Trench width [mm]
L - Trench Length [mm]

Ts/Tr °C	L [mm]										
	800	1000	1300	1600	1900	2200	2500	2800	3200	3600	4000
90/70	245	343	489	636	783	930	1077	1223	1419	1615	1811
75/65	191	267	382	497	611	726	840	955	1108	1261	1413
70/55	153	214	306	398	490	582	674	766	888	1011	1134
55/45	95	133	191	248	305	362	419	477	553	629	705
50/40	74	104	149	194	238	283	328	372	432	492	551

Heat outputs [W] according to EN 442 for the room air temperature Ti= 20°C

VK15-14/25/L-22

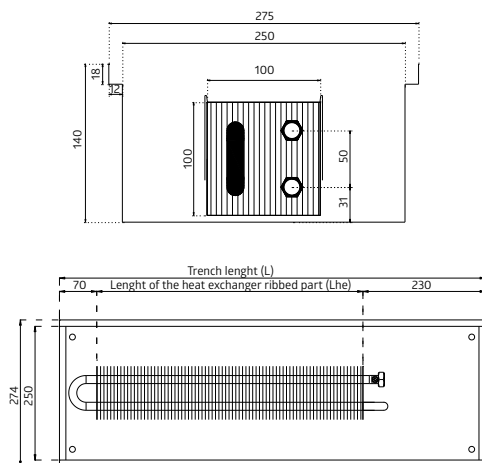

DIMENSIONS	UNIT [mm]
Trench height (H)	140
Trench width (W)	250
Grille width (Wg)	274
Trench length (L)	800 ÷ 4000
Lenght of the heat exchanger ribbed part (Lhe)	L - 300
Fin type	22
CONNECTIONS	TYPE
Connection threads	IT 3/4" one-sided
Side connection to be choosen	(Standard Right - P, optional Left - L)
ACCESORIES	TYPE
Grille H=18 mm	roll-up/linear/modular
Aluminium frame	type L or F
Assembly cover	on request

Ts/Tr °C	L [mm]										
	800	1000	1300	1600	1900	2200	2500	2800	3200	3600	4000
90/70	324	454	648	843	1037	1232	1426	1620	1880	2139	2398
75/65	253	354	506	658	810	961	1113	1265	1467	1670	1872
70/55	203	284	406	528	649	771	893	1015	1177	1339	1502
55/45	126	177	252	328	404	480	555	631	732	833	934
50/40	99	138	197	257	316	375	434	493	572	651	730

Heat outputs [W] according to EN 442 for the room air temperature Ti= 20°C

140 mm height

VK15

DIMENSIONS	UNIT [mm]
Trench height (H)	140
Trench width (W)	290
Grille width (Wg)	314
Trench length (L)	800 ÷ 4000
Length of the heat exchanger ribbed part (Lhe)	L - 300
Fin type	23
CONNECTIONS	TYPE
Connection threads	IT 3/4" one-sided
Side connection to be choosen	(Standard Right - P, optional Left - L)
ACCESORIES	TYPE
Grille H=18 mm	roll-up/linear/modular
Aluminium frame	type L or F
Assembly cover	on request

VK15-14/29/L-23

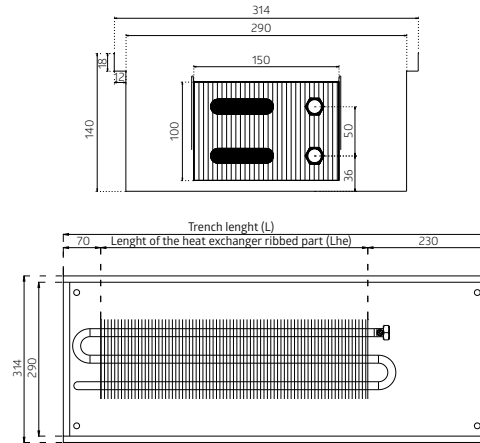

Ts/Tr °C	L [mm]										
	800	1000	1300	1600	1900	2200	2500	2800	3200	3600	4000
90/70	441	617	881	1146	1410	1675	1939	2203	2556	2908	3261
75/65	344	482	688	894	1101	1307	1514	1720	1995	2270	2546
70/55	276	386	552	717	883	1048	1214	1379	1600	1821	2042
55/45	172	240	343	446	549	652	755	858	996	1133	1270
50/40	134	188	268	349	429	510	590	671	778	885	993

Please remember:

Order code for heaters type VK15:

VK15-H/W/L-fin type

where:

H - Trench height [mm]
W - Trench width [mm]
L - Trench Length [mm]

Heat outputs [W] according to EN 442 for the room air temperature Ti= 20°C

DIMENSIONS	UNIT [mm]
Trench height (H)	140
Trench width (W)	380
Grille width (Wg)	404
Trench length (L)	800 ÷ 4000
Length of the heat exchanger ribbed part (Lhe)	L - 300
Fin type	24
CONNECTIONS	TYPE
Connection threads	IT 3/4" one-sided
Side connection to be choosen	(Standard Right - P, optional Left - L)
ACCESORIES	TYPE
Grille H=18 mm	roll-up/linear/modular
Aluminium frame	type L or F
Assembly cover	on request

VK15-14/38/L-24

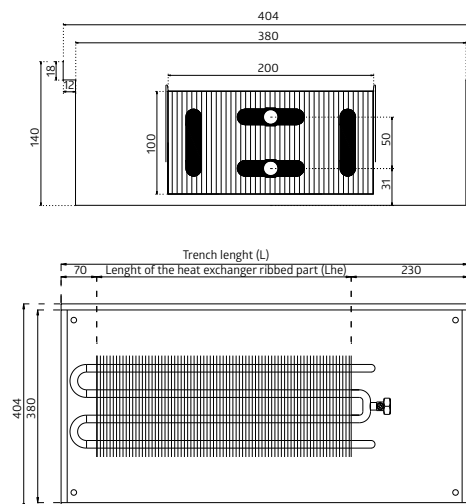

Ts/Tr °C	L [mm]										
	800	1000	1300	1600	1900	2200	2500	2800	3200	3600	4000
90/70	595	833	1190	1547	1904	2261	2618	2975	3451	3927	4403
75/65	465	650	929	1208	1486	1765	2044	2323	2694	3066	3437
70/55	373	522	745	969	1192	1416	1639	1863	2161	2459	2757
55/45	232	324	464	603	742	881	1020	1159	1344	1530	1715
50/40	181	254	362	471	580	688	797	906	1051	1196	1341

Heat outputs [W] according to EN 442 for the room air temperature Ti= 20°C

VK15

250 mm height

VK15-25/20/L-22

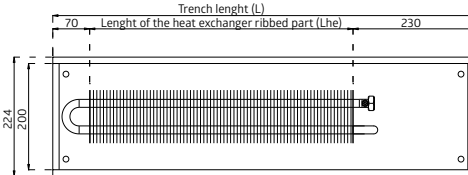
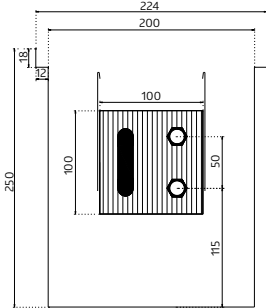

DIMENSIONS	UNIT [mm]
Trench height (H)	250
Trench width (W)	200
Grille width (Wg)	224
Trench length (L)	800 ÷ 4000
Lenght of the heat exchanger ribbed part (Lhe)	L - 300
Fin type	22
CONNECTIONS	TYPE
Connection threads	IT 3/4" one-sided
Side connection to be choosen	(Standard Right - P, optional Left - L)
ACCESORIES	TYPE
Grille H=18 mm	roll-up/linear/modular
Aluminium frame	type L or F
Assembly cover	on request

Please remember:

Order code for heaters type VK15:

VK15-H/W/L-fin type

where:

- H - Trench height [mm]
- W - Trench width [mm]
- L - Trench Length [mm]

Ts/Tr °C	L [mm]										
	800	1000	1300	1600	1900	2200	2500	2800	3200	3600	4000
90/70	443	621	886	1152	1418	1684	1950	2216	2571	2925	3280
75/65	346	484	692	900	1107	1315	1522	1730	2007	2284	2560
70/55	277	388	555	721	888	1054	1221	1387	1609	1831	2053
55/45	173	242	345	449	552	656	760	863	1001	1140	1278
50/40	135	189	270	351	432	513	594	675	783	891	999

Heat outputs [W] according to EN 442 for the room air temperature Ti= 20°C

VK15-25/25/L-22

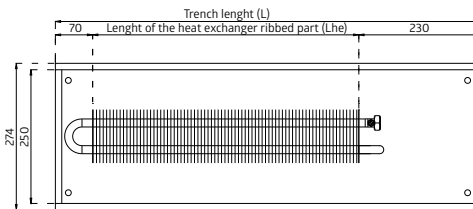
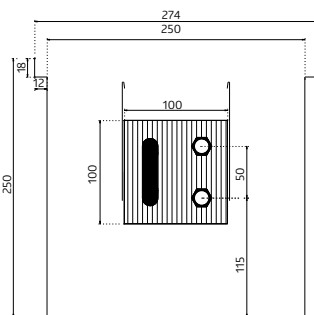

DIMENSIONS	UNIT [mm]
Trench height (H)	250
Trench width (W)	250
Grille width (Wg)	274
Trench length (L)	800 ÷ 4000
Lenght of the heat exchanger ribbed part (Lhe)	L - 300
Fin type	22
CONNECTIONS	TYPE
Connection threads	IT 3/4" one-sided
Side connection to be choosen	(Standard Right - P, optional Left - L)
ACCESORIES	TYPE
Grille H=18 mm	roll-up/linear/modular
Aluminium frame	type L or F
Assembly cover	on request

Ts/Tr °C	L [mm]										
	800	1000	1300	1600	1900	2200	2500	2800	3200	3600	4000
90/70	496	695	993	1291	1588	1886	2184	2482	2879	3276	3673
75/65	388	543	775	1008	1240	1473	1705	1938	2248	2558	2868
70/55	311	435	622	808	994	1181	1367	1554	1802	2051	2300
55/45	193	271	387	503	619	735	851	967	1122	1276	1431
50/40	151	212	302	393	484	574	665	756	877	997	1118

Heat outputs [W] according to EN 442 for the room air temperature Ti= 20°C

250 mm height

VK15

VK15-25/29/L-23

DIMENSIONS	UNIT [mm]
Trench height (H)	250
Trench width (W)	290
Grille width (Wg)	314
Trench lenght (L)	800 ÷ 4000
Lenght of the heat exchanger ribbed part (Lhe)	L - 300
Fin type	23
CONNECTIONS	TYPE
Connection threads	IT 3/4" one-sided
Side connection to be choosen	(Standard Right - P, optional Left - L)
ACCESORIES	TYPE
Grille H=18 mm	roll-up/linear/modular
Aluminium frame	type L or F
Assembly cover	on request

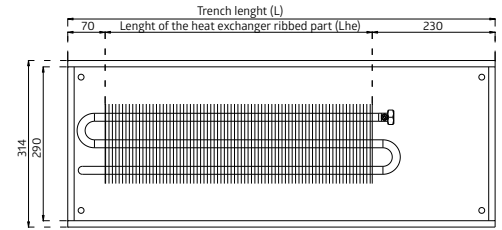
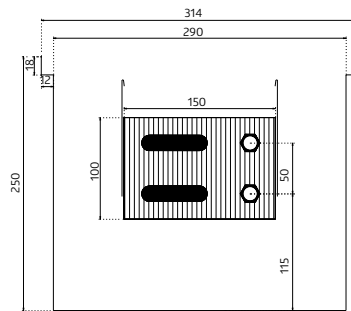

Ts/Tr °C	L [mm]										
	800	1000	1300	1600	1900	2200	2500	2800	3200	3600	4000
90/70	642	898	1284	1669	2054	2439	2824	3209	3722	4236	4749
75/65	501	701	1002	1303	1603	1904	2204	2505	2906	3307	3707
70/55	402	563	804	1045	1286	1527	1768	2009	2330	2652	2973
55/45	250	350	500	650	800	950	1100	1250	1450	1650	1850
50/40	195	274	391	508	625	742	860	977	1133	1290	1446

Please remember:

Order code for heaters type VK15:

VK15-H/W/L-fin type

where:

H - Trench height [mm]
W - Trench width [mm]
L - Trench Length [mm]

Heat outputs [W] according to EN 442 for the room air temperature Ti= 20°C

DIMENSIONS	UNIT [mm]
Trench height (H)	250
Trench width (W)	380
Grille width (Wg)	404
Trench lenght (L)	800 ÷ 4000
Lenght of the heat exchanger ribbed part (Lhe)	L - 300
Fin type	24
CONNECTIONS	TYPE
Connection threads	IT 3/4" one-sided
Side connection to be choosen	(Standard Right - P, optional Left - L)
ACCESORIES	TYPE
Grille H=18 mm	roll-up/linear/modular
Aluminium frame	type L or F
Assembly cover	on request

VK15-25/38/L-24

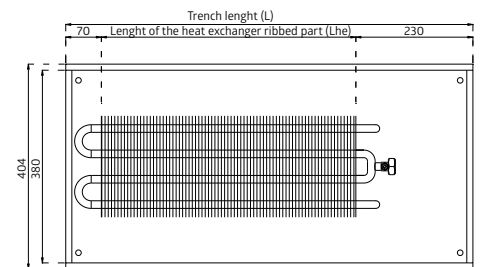
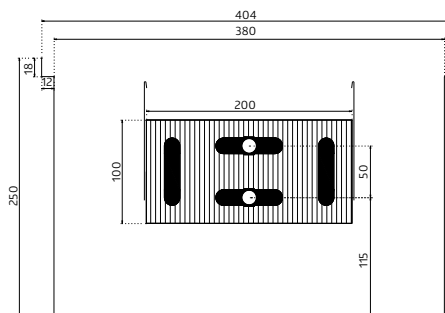

Ts/Tr °C	L [mm]										
	800	1000	1300	1600	1900	2200	2500	2800	3200	3600	4000
90/70	897	1256	1795	2333	2871	3410	3948	4487	5205	5922	6640
75/65	701	981	1401	1821	2242	2662	3082	3503	4063	4623	5184
70/55	562	787	1124	1461	1798	2135	2472	2809	3258	3708	4157
55/45	350	489	699	909	1119	1328	1538	1748	2027	2307	2587
50/40	273	382	546	710	874	1038	1202	1366	1585	1803	2022

Heat outputs [W] according to EN 442 for the room air temperature Ti= 20°C

VK15

350 mm height

VK15-35/20/L-22

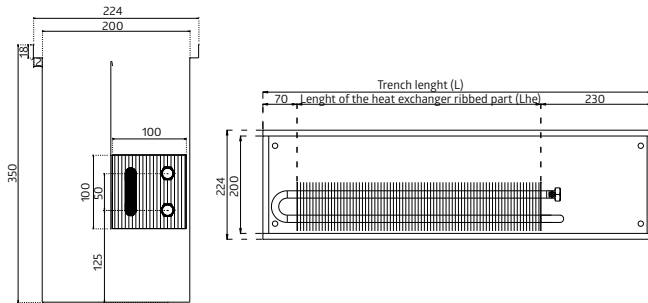

DIMENSIONS	UNIT [mm]
Trench height (H)	350
Trench width (W)	200
Grille width (Wg)	224
Trench length (L)	800 ÷ 4000
Lenght of the heat exchanger ribbed part (Lhe)	L - 300
Fin type	22
CONNECTIONS	TYPE
Connection threads	IT 3/4" one-sided
Side connection to be choosen	(Standard Right - P, optional Left - L)
ACCESORIES	TYPE
Grille H=18 mm	roll-up/linear/modular
Aluminium frame	type L or F
Assembly cover	on request

Please remember:

Order code for heaters type VK15:

VK15-H/W/L-fin type

where:

H - Trench height [mm]
W - Trench width [mm]
L - Trench Length [mm]

Ts/Tr °C	L [mm]										
	800	1000	1300	1600	1900	2200	2500	2800	3200	3600	4000
90/70	534	747	1067	1387	1707	2027	2348	2668	3095	3521	3948
75/65	417	583	833	1083	1333	1583	1833	2083	2416	2749	3082
70/55	334	468	668	868	1069	1269	1470	1670	1937	2205	2472
55/45	208	291	416	540	665	790	914	1039	1205	1372	1538
50/40	162	227	325	422	520	617	715	812	942	1072	1202

Heat outputs [W] according to EN 442 for the room air temperature Ti= 20°C

VK15-35/29/L-23

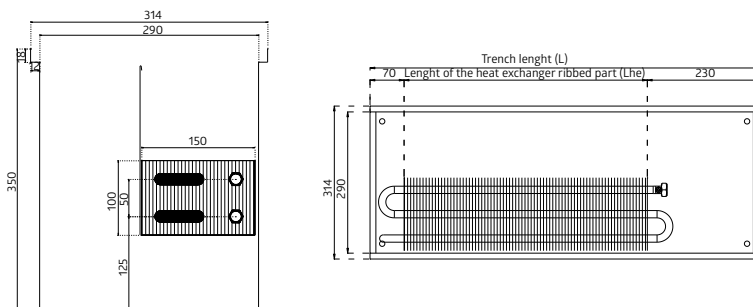

DIMENSIONS	UNIT [mm]
Trench height (H)	350
Trench width (W)	290
Grille width (Wg)	314
Trench length (L)	800 ÷ 4000
Lenght of the heat exchanger ribbed part (Lhe)	L - 300
Fin type	23
CONNECTIONS	TYPE
Connection threads	IT 3/4" one-sided
Side connection to be choosen	(Standard Right - P, optional Left - L)
ACCESORIES	TYPE
Grille H=18 mm	roll-up/linear/modular
Aluminium frame	type L or F
Assembly cover	on request

Ts/Tr °C	L [mm]										
	800	1000	1300	1600	1900	2200	2500	2800	3200	3600	4000
90/70	888	1244	1777	2310	2843	3376	3909	4442	5153	5863	6574
75/65	694	971	1387	1803	2219	2635	3051	3468	4022	4577	5132
70/55	556	779	1112	1446	1780	2114	2447	2781	3226	3671	4116
55/45	346	484	692	900	1107	1315	1523	1730	2007	2284	2561
50/40	270	379	541	703	865	1028	1190	1352	1569	1785	2001

Heat outputs [W] according to EN 442 for the room air temperature Ti= 20°C

350 mm height

VK15

VK15-35/38/L-24

DIMENSIONS	UNIT [mm]
Trench height (H)	350
Trench width (W)	380
Grille width (Wg)	404
Trench length (L)	800 ÷ 4000
Length of the heat exchanger ribbed part (Lhe)	L - 300
Fin type	24
CONNECTIONS	TYPE
Connection threads	IT 3/4" one-sided
Side connection to be choosen	(Standard Right - P, optional Left - L)
ACCESORIES	TYPE
Grille H=18 mm	roll-up/linear/modular
Aluminium frame	type L or F
Assembly cover	on request

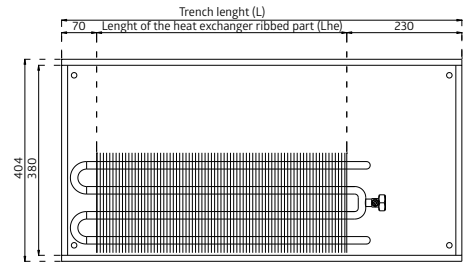
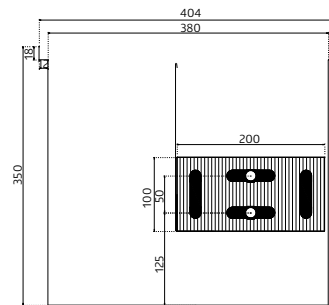

Ts/Tr °C	L [mm]										
	800	1000	1300	1600	1900	2200	2500	2800	3200	3600	4000
90/70	1050	1471	2101	2731	3361	3992	4622	5252	6092	6933	7773
75/65	820	1148	1640	2132	2624	3116	3608	4100	4756	5412	6068
70/55	658	921	1315	1710	2104	2499	2894	3288	3814	4340	4867
55/45	409	573	818	1064	1309	1555	1800	2046	2373	2701	3028
50/40	320	448	640	831	1023	1215	1407	1599	1855	2111	2367

Please remember:

Order code for heaters type VK15:

VK15-H/W/L-fin type

where:
H - Trench height [mm]
W - Trench width [mm]
L - Trench Length [mm]

Heat outputs [W] according to EN 442 for the room air temperature Ti= 20°C

VK15

540 mm height

VK15-54/20/L-22

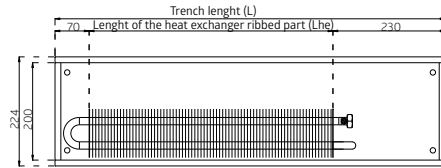
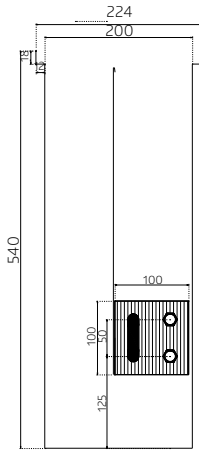

DIMENSIONS	UNIT [mm]
Trench height (H)	540
Trench width (W)	200
Grille width (Wg)	224
Trench length (L)	800 ÷ 4000
Lenght of the heat exchanger ribbed part (Lhe)	L - 300
Fin type	22
CONNECTIONS	TYPE
Connection threads	IT 3/4" one-sided
Side connection to be choosen	(Standard Right - P, optional Left - L)
ACCESORIES	TYPE
Grille H=18 mm	roll-up/linear/modular
Aluminium frame	type L or F
Assembly cover	on request

Please remember:

Order code for heaters type VK15:

VK15-H/W/L-fin type

where:

- H - Trench height [mm]
- W - Trench width [mm]
- L - Trench Length [mm]

Ts/Tr °C	L [mm]										
	800	1000	1300	1600	1900	2200	2500	2800	3200	3600	4000
90/70	785	1099	1571	2042	2513	2984	3455	3926	4554	5183	5811
75/65	613	858	1226	1594	1962	2329	2697	3065	3555	4046	4536
70/55	492	688	983	1278	1573	1868	2163	2458	2851	3245	3638
55/45	306	428	612	795	979	1162	1346	1529	1774	2019	2264
50/40	239	335	478	622	765	908	1052	1195	1387	1578	1769

Heat outputs [W] according to EN 442 for the room air temperature Ti= 20°C

VK15-54/29/L-23

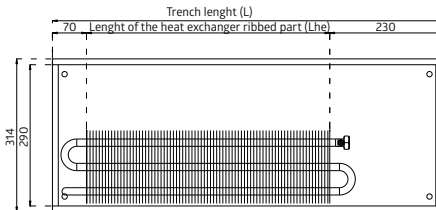
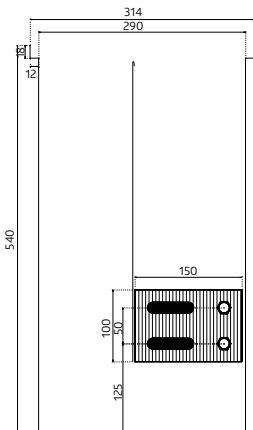

DIMENSIONS	UNIT [mm]
Trench height (H)	540
Trench width (W)	290
Grille width (Wg)	314
Trench length (L)	800 ÷ 4000
Lenght of the heat exchanger ribbed part (Lhe)	L - 300
Fin type	23
CONNECTIONS	TYPE
Connection threads	IT 3/4" one-sided
Side connection to be choosen	(Standard Right - P, optional Left - L)
ACCESORIES	TYPE
Grille H=18 mm	roll-up/linear/modular
Aluminium frame	type L or F
Assembly cover	on request

Ts/Tr °C	L [mm]										
	800	1000	1300	1600	1900	2200	2500	2800	3200	3600	4000
90/70	1278	1790	2557	3324	4091	4858	5625	6392	7415	8438	9460
75/65	998	1397	1996	2595	3194	3792	4391	4990	5788	6587	7385
70/55	800	1121	1601	2081	2561	3042	3522	4002	4642	5283	5923
55/45	498	697	996	1295	1594	1892	2191	2490	2888	3287	3685
50/40	389	545	778	1012	1246	1479	1713	1946	2257	2569	2880

Heat outputs [W] according to EN 442 for the room air temperature Ti= 20°C

540 mm height

VK15

VK15-54/38/L-24

DIMENSIONS	UNIT [mm]
Trench height (H)	540
Trench width (W)	380
Grille width (Wg)	404
Trench length (L)	800 ÷ 4000
Length of the heat exchanger ribbed part (Lhe)	L - 300
Fin type	24
CONNECTIONS	TYPE
Connection threads	IT 3/4" one-sided
Side connection to be choosen	(Standard Right - P, optional Left - L)
ACCESORIES	TYPE
Grille H=18 mm	roll-up/linear/modular
Aluminium frame	type L or F
Assembly cover	on request

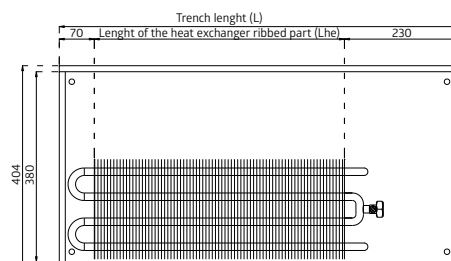
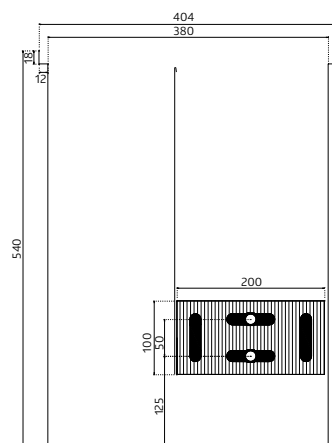

Ts/Tr °C	L [mm]										
	800	1000	1300	1600	1900	2200	2500	2800	3200	3600	4000
90/70	1790	2506	3580	4655	5729	6803	7877	8951	10383	11815	13247
75/65	1398	1957	2795	3634	4472	5311	6149	6988	8106	9224	10342
70/55	1121	1569	2242	2914	3587	4259	4931	5604	6501	7397	8294
55/45	697	976	1395	1813	2232	2650	3068	3487	4045	4603	5160
50/40	545	763	1090	1417	1744	2071	2398	2725	3161	3597	4033

Please remember:

Order code for heaters type VK15:

VK15-H/W/L-fin type

where:
H - Trench height [mm]
W - Trench width [mm]
L - Trench Length [mm]

Heat outputs [W] according to EN 442 for the room air temperature Ti= 20°C

Correction factors

Correction factors for Verano heaters type VK15 for parameters other than 75/65/20°C.

Heating medium temperature [°C]		Room air temperature T_i [°C]						
T_s	T_r	5	8	12	16	20	25	32
90	85	1,975	1,878	1,751	1,626	1,504	1,354	1,152
	80	1,894	1,798	1,673	1,549	1,428	1,281	1,082
	75	1,814	1,719	1,595	1,473	1,354	1,209	1,014
	70	1,735	1,642	1,519	1,399	1,281	1,138	0,946
85	80	1,814	1,719	1,595	1,473	1,354	1,209	1,014
	75	1,735	1,642	1,519	1,399	1,281	1,138	0,946
	70	1,657	1,565	1,443	1,325	1,209	1,069	0,880
	65	1,580	1,489	1,369	1,252	1,138	1,000	0,815
80	75	1,657	1,565	1,443	1,325	1,209	1,069	0,880
	70	1,580	1,489	1,369	1,252	1,138	1,000	0,815
	65	1,504	1,414	1,296	1,181	1,069	0,933	0,751
	60	1,428	1,340	1,224	1,110	1,000	0,867	0,689
75	70	1,504	1,414	1,296	1,181	1,069	0,933	0,751
	65	1,428	1,340	1,224	1,110	1,000	0,867	0,689
	60	1,354	1,267	1,152	1,041	0,933	0,802	0,628
	55	1,281	1,195	1,082	0,973	0,867	0,738	0,568
70	65	1,354	1,267	1,152	1,041	0,933	0,802	0,628
	60	1,281	1,195	1,082	0,973	0,867	0,738	0,568
	55	1,209	1,124	1,014	0,906	0,802	0,676	0,511
	50	1,138	1,055	0,946	0,841	0,738	0,616	0,455
65	60	1,209	1,124	1,014	0,906	0,802	0,676	0,511
	55	1,138	1,055	0,946	0,841	0,738	0,616	0,455
	50	1,069	0,986	0,880	0,776	0,676	0,557	0,400
	45	1,000	0,919	0,815	0,713	0,616	0,499	0,348
60	55	1,069	0,986	0,880	0,776	0,676	0,557	0,400
	50	1,000	0,919	0,815	0,713	0,616	0,499	0,348
	45	0,933	0,854	0,751	0,652	0,557	0,444	0,298
	40	0,867	0,789	0,689	0,592	0,499	0,390	0,249
55	50	0,933	0,854	0,751	0,652	0,557	0,444	0,298
	45	0,867	0,789	0,689	0,592	0,499	0,390	0,249
	40	0,802	0,726	0,628	0,534	0,444	0,338	0,204
	35	0,738	0,664	0,568	0,477	0,390	0,288	0,160
50	45	0,802	0,726	0,628	0,534	0,444	0,338	0,204
	40	0,738	0,664	0,568	0,477	0,390	0,288	0,160
	35	0,676	0,604	0,511	0,422	0,338	0,240	0,120
45	40	0,676	0,604	0,511	0,422	0,338	0,240	0,120
	35	0,616	0,545	0,455	0,369	0,288	0,195	0,083

How to choose the most efficient heater?

Calculated thermal power requirement is 1130 W.

choose the heater VK15-14/38/360-24 (3066W for 75/65/20°C).

Planned supply, return and indoor temperatures: $T_s/T_r/T_i=50/40/20^\circ\text{C}$. For this parameters we read the temperature correction factor which is 0.390.

It follows that the draft heater reaches the power output 1196 W for parameters 50/40/20°C, while the parameters 75/65/20°C get 3066 W.

Then we divide the calculated thermal power (1130 W) by correction factor (0.390) and we get heat output needed which is 2897 W, according to which we

Correction factors for Verano heaters type VK15 taking into account the type of grille

GRILLE TYPE	AIR FLOW	CORRECTION FACTOR
Aluminium grille closed profile	61,6%	1,00
Aluminium grille I-beam profile	57,6%	0,99
Wooden grille	52%	0,97
Modular grille	60,8%	1,00
Linear grille	58%	0,99
Stainless steel grille	61,2%	1,00

Water capacity [dm³]

H = 75, 90, 110 mm

W [mm]	L [mm]										
	800	1000	1300	1600	1900	2200	2500	2800	3200	3600	4000
200	0,18	0,25	0,34	0,43	0,52	0,62	0,71	0,80	0,92	1,05	1,17
250	0,18	0,25	0,34	0,43	0,52	0,62	0,71	0,80	0,92	1,05	1,17
290	0,28	0,37	0,51	0,65	0,79	0,92	1,06	1,20	1,39	1,57	1,75
380	0,37	0,49	0,68	0,86	1,05	1,23	1,42	1,60	1,85	2,09	2,34

H = 140, 250 mm

W [mm]	L [mm]										
	800	1000	1300	1600	1900	2200	2500	2800	3200	3600	4000
200	0,37	0,49	0,68	0,86	1,05	1,23	1,42	1,60	1,85	2,09	2,34
250	0,37	0,49	0,68	0,86	1,05	1,23	1,42	1,60	1,85	2,09	2,34
290	0,55	0,74	1,02	1,29	1,57	1,85	2,12	2,40	2,77	3,14	3,51
380	0,74	0,99	1,35	1,72	2,09	2,46	2,83	3,20	3,69	4,19	4,68

H = 350, 540 mm

W [mm]	L [mm]										
	800	1000	1300	1600	1900	2200	2500	2800	3200	3600	4000
200	0,37	0,49	0,68	0,86	1,05	1,23	1,42	1,60	1,85	2,09	2,34
290	0,55	0,74	1,02	1,29	1,57	1,85	2,12	2,40	2,77	3,14	3,51
380	0,74	0,99	1,35	1,72	2,09	2,46	2,83	3,20	3,69	4,19	4,68

VK15

Pressure losses [Pa]

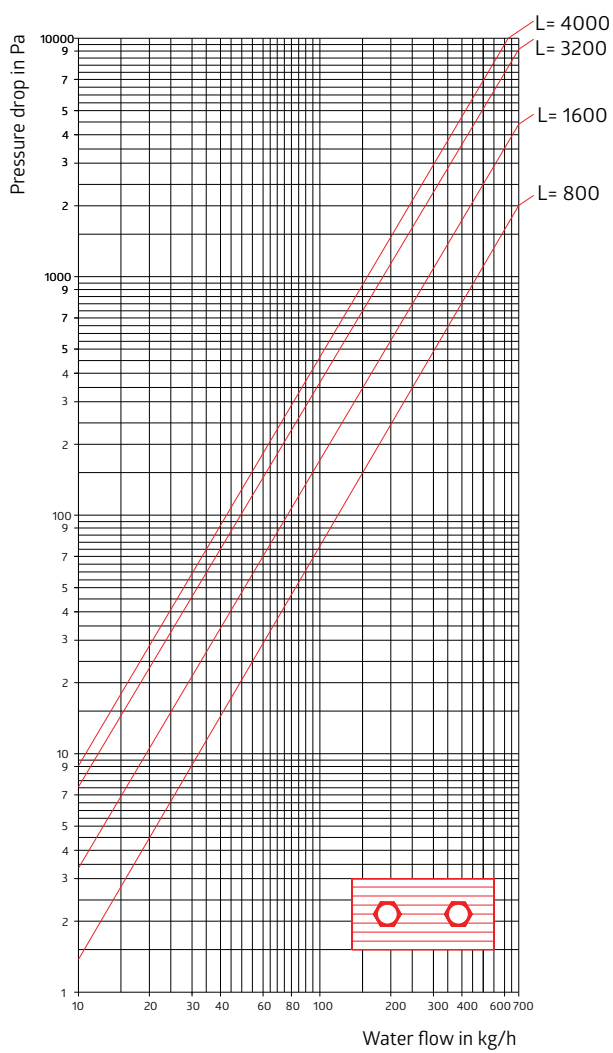

Height: 75, 90, 110 mm
Width: 200, 250 mm

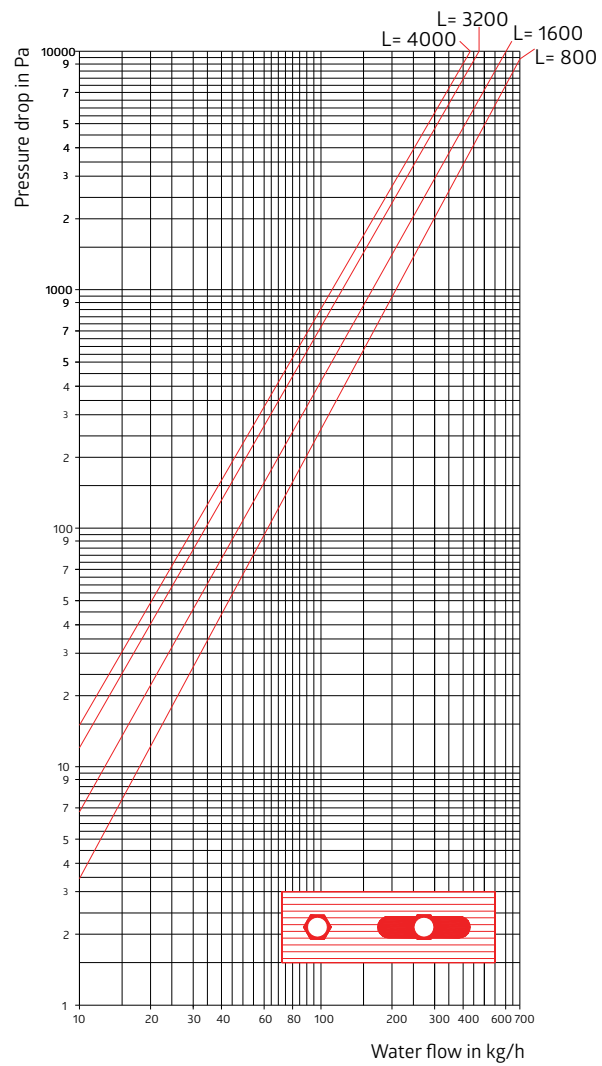

Height: 75, 90, 110 mm
Width: 290 mm

Pressure losses [Pa]

VK15

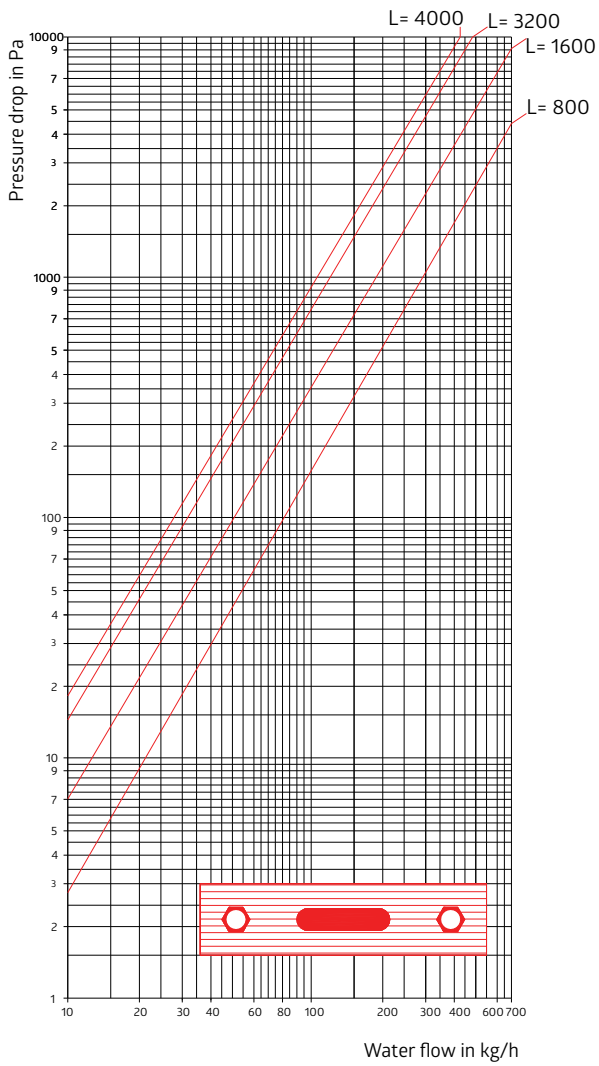

Height: 75, 90, 110 mm
Width: 380 mm

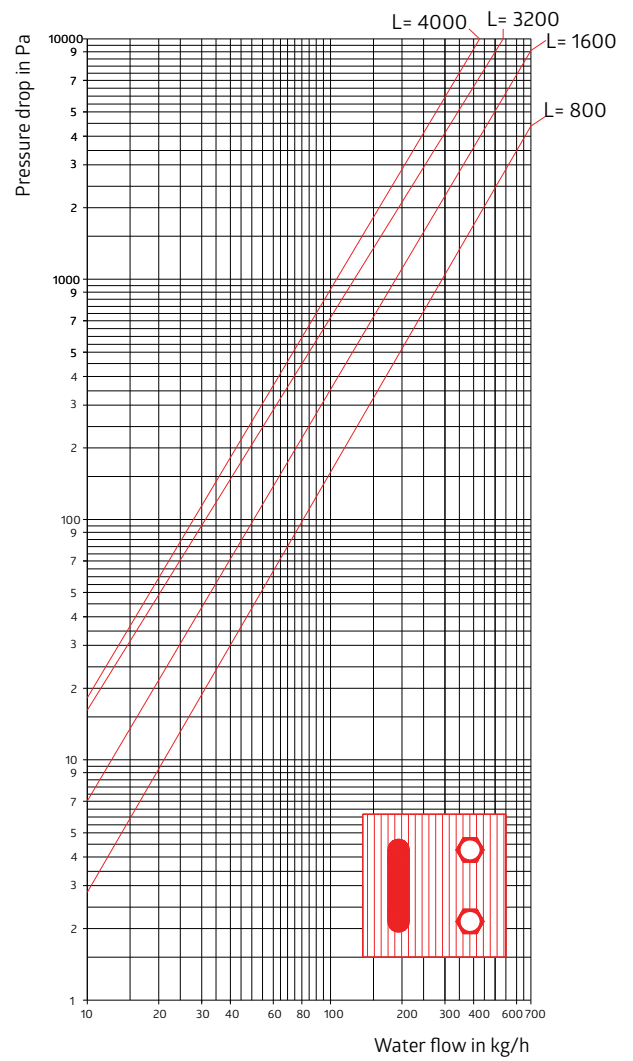

Height: 140, 250, 350, 540 mm
Width: 250 mm

VK15

Pressure losses [Pa]

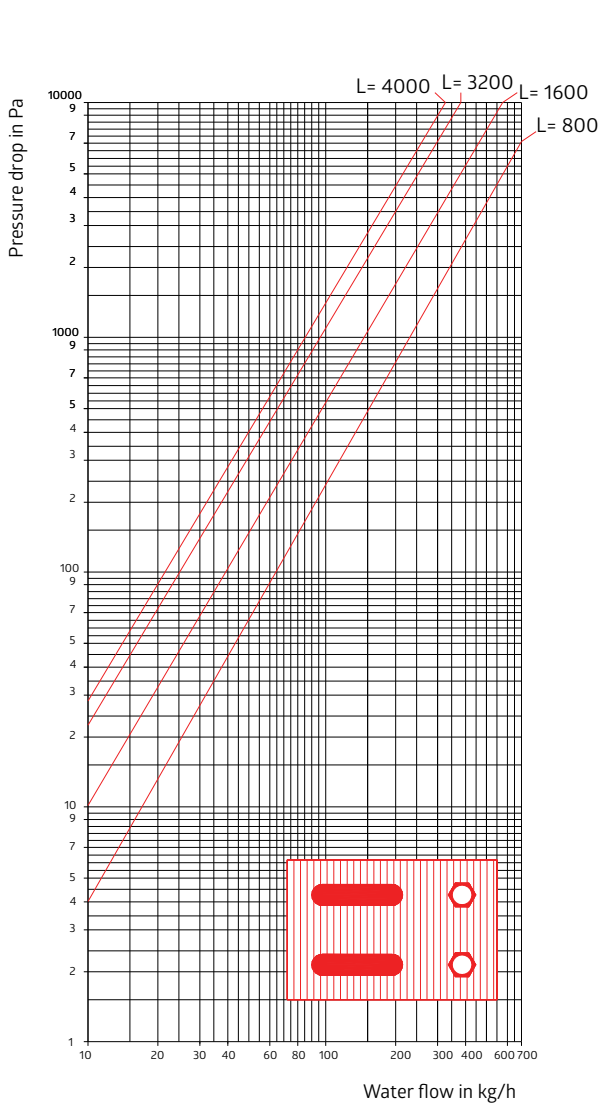

Height: 140, 250, 350, 540 mm
Width: 290 mm

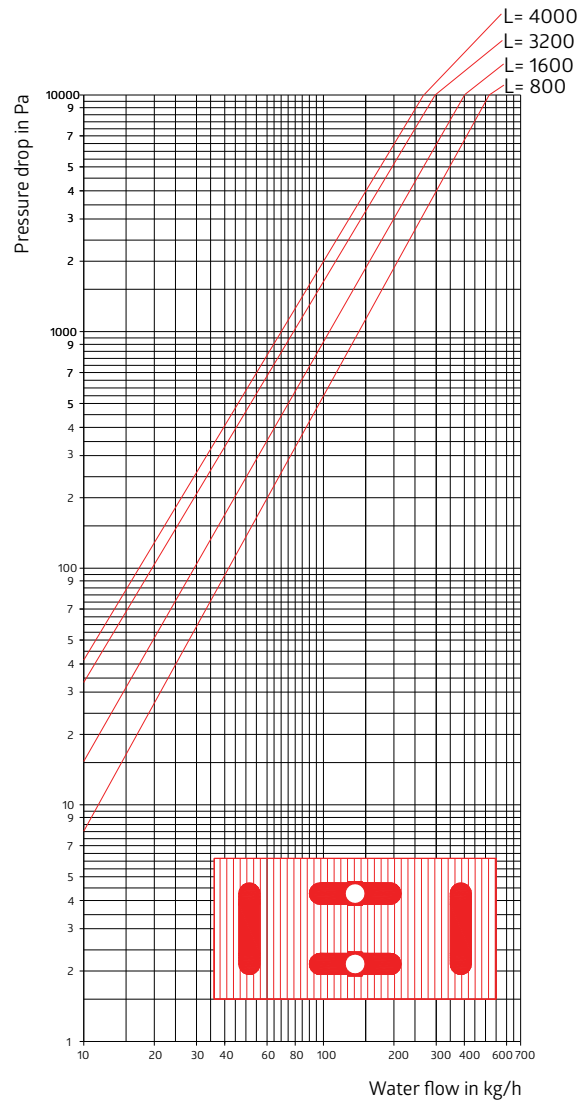

Height: 140, 250, 350, 540 mm
Width: 380 mm

Frame for trench heaters and climaconvectors

Frame details

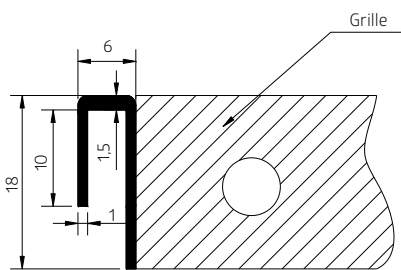

Frame type L

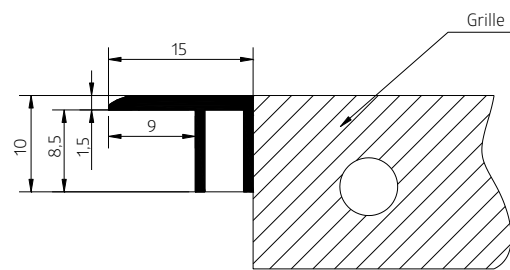

Frame type F

Frame assembly instruction

Aluminium frame type L is a decorative element, and type F apart of the decorative function is also as a masking element which can cover the space between the floor and the duct of the trench heater.

The frame F is supplied as a cut off elements for self-assembly. Assembly of the frame type F must be done by using a silicone glue. The manufacturer is not liable for problems associated with frame assembling for trench casing deformation caused by the improper installation of the heater..

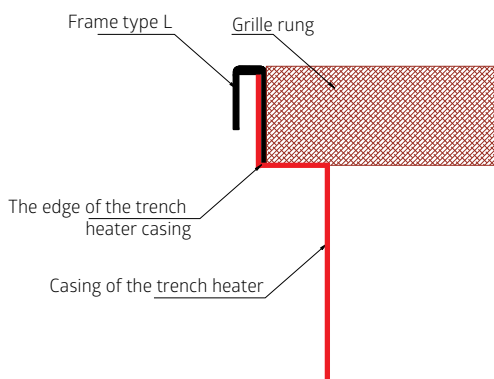

Frame type L

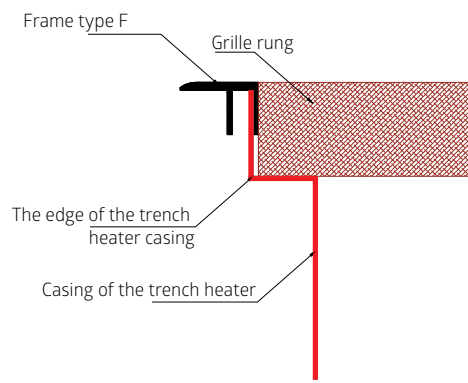

Frame type F

FRAME

Grilles for trench heaters and climaconvectors

Roll-up wooden grille

The grille is made of natural wood

Standard:

Spacings (sleeves) between the rungs are made of black PVC.

Option:

- Spacings (sleeves) are also available in colors:
 - gray WG-15
 - beige W8-29
 - light brown RAL 8256
 - dark brown RAL 8352
- wooden spacing (beech unvarnished, L = 17 mm)

The grille is only available in a roll-up version.

The maximum length of one grille section is 6000 mm

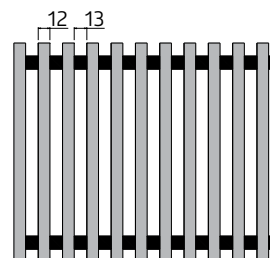

Top view

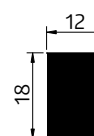

Cross-section of a wooden rung

Type of the grille	Name of the grille	Order code
Roll-up wooden grille	Roll-up oak grille	ZD-1,8/W/L
	Roll-up ash grille	ZJ-1,8/W/L
	Roll-up beech grille	ZB-1,8/W/L
	Roll-up merbau grille	ZM-1,8/W/L
	Roll-up jatoba grille	ZJB-1,8/W/L

Roll-up aluminium grille

The grille is made of aluminium - profile closed

The grille options:

- natural aluminium
- aluminium painted in RAL
- anodized aluminium
- aluminium - wood imitation (profile closed only)

Standard:

Spacings (sleeves) between rungs as a standard are made of black PVC.

Opcja:

- Spacings (sleeves) are also available in colors:
 - gray WG-15
 - beige W8-29
 - light brown RAL 8256
 - dark brown RAL 8352

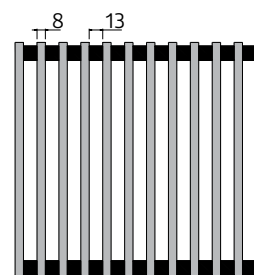

Top view

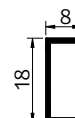

Cross-section of aluminium grille - profile closed

Type of the grille	Name of the grille	Order code
Roll-up aluminium grille - profile closed	Roll-up natural aluminium grille - profile closed	ZAL-1,8/W/L
	Roll-up painted in RAL aluminium grille - profile closed	ZRAL-1,8/W/L
	Roll-up anodized aluminium grille - profile closed	ZAAL-1,8/W/L
	Roll-up wood imitation aluminium grille - profile closed	ZIAL-1,8/W/L

FRAME

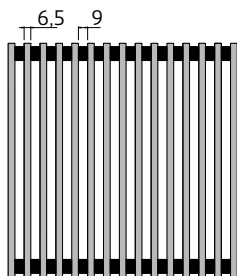

Top view

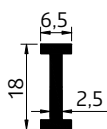

Cross-section of grille
- I-beam profile

Roll-up aluminium grille – I-beam profile

The grille is made of aluminium – I-beam profile

- The grille options:
- natural aluminium
 - aluminium painted in RAL
 - anodized aluminium

Standard:

Spacings (sleeves) between rungs as a standard are made of black PVC.

Option:

- Spacings (sleeves) are also available in colors:
 - gray WG-15
 - beige W8-29
 - light brown RAL 8256
 - dark brown RAL 8352



Type of the grille	Name of the grille	Order code
Roll-up aluminium grille – I-beam profile	Roll-up natural aluminium grille – I-beam profile	ZDW-1,8/W/L
	Roll-up painted in RAL aluminium grille – I-beam profile	ZRDW-1,8/W/L
	Roll-up anodized aluminium grille – I-beam profile	ZADW-1,8/W/L

Linear aluminium grille

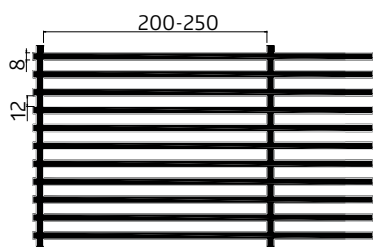

Top view

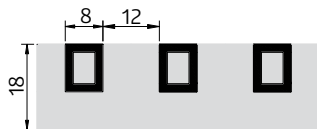

Cross-section of linear grille
painted in RAL

The grille is made of aluminium – profile closed.

The grill is made in total of aluminium.

The grille is only available in RAL colours.

Standard colour is black RAL 9005.



Type of the grille	Name of the grille	Order code
Linear grille	Linear painted in RAL aluminium grille – profile closed	ALWR-1,8/W/L

FRAME

Modular aluminium grille

The grille is made of aluminium.

The grille options:

- natural aluminium
- aluminium painted in RAL
- anodized aluminium
- aluminium - wood imitation

Spacings (rung fasteners) are made of black plastic.

The length of single module is 440 mm.

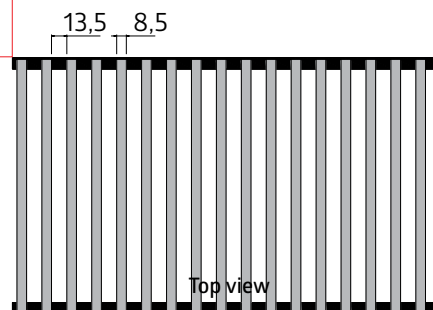

Type of the grille	Name of the grille	Order code
Modular aluminium grille – profile closed	Modular natural aluminium grille – profile closed	MAL-1,8/W/L
	Modular painted in RAL aluminium grille – profile closed	MRAL-1,8/W/L
	Modular anodized aluminium grille – profile closed	MAAL-1,8/W/L
	Modular wood imitation aluminium grille – profile closed	MIAL-1,8/W/L

Linear stainless steel grille

The grille is available only as a rigid version.

The maximum length of one section of the grille is 2000 mm.

Grille length longer than 2000mm are made of several elements of equal lengths.

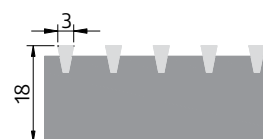
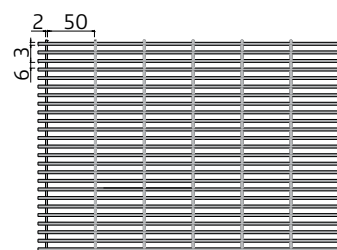

Cross-section of stainless steel grille

Type of the grille	Name of the grille	Order code
Stainless steel grille	Linear stainless steel grille	SN-1,8/W/L

FRAME

Wooden grille



Oak

Ash

Beech

Merbau

Jatoba

Wood imitation aluminium grille



Cherry
WDWIS01

Pine
WDSN01

Beech
WDBK01

Bog Oak
WDDB01

Golden oak
WDZD01



Walnut
WDOR01

Mahogany
WDMH01

Anodized aluminium grille



Satin 01

Medium Brown 02

Black 05

Stainless steel 07

Gold 00

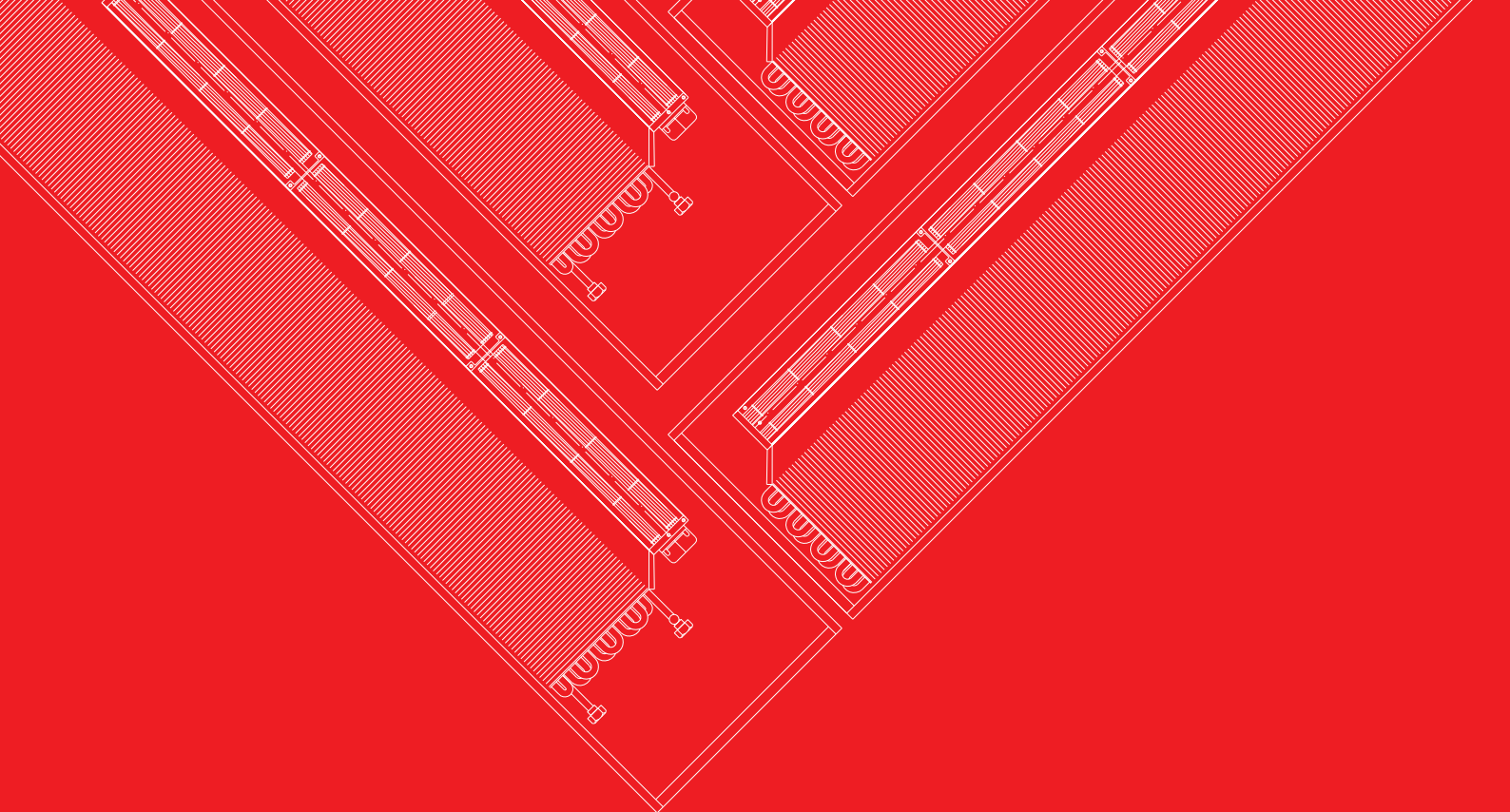

MDL SOLUTIONS
NATIONAL DISTRIBUTOR

2275 UPPER MIDDLE RD, E
OAKVILLE, ONTARIO
L6H 203

TEL: 289 799-3414; EMAIL:
GENERAL@MDLSOLN.COM



www.mdlsoln.com

Technical catalogue 2015_01

After completion the edition of the directory on the 21.01.2015, may have been some changes in the products listed in.
The manufacturer reserves the right to make changes to the design, color and specification.
Illustrations may include optional accessories. Printing technology can affect the differences in the forward colors.
Please contact to your local sales agent for the newest information of Verano products.