

**PTAC HORIZONTAL AND VERTICAL PACKAGED TERMINAL UNITS**  
MDL: PROFESSIONAL GRADE HVAC SOLUTIONS

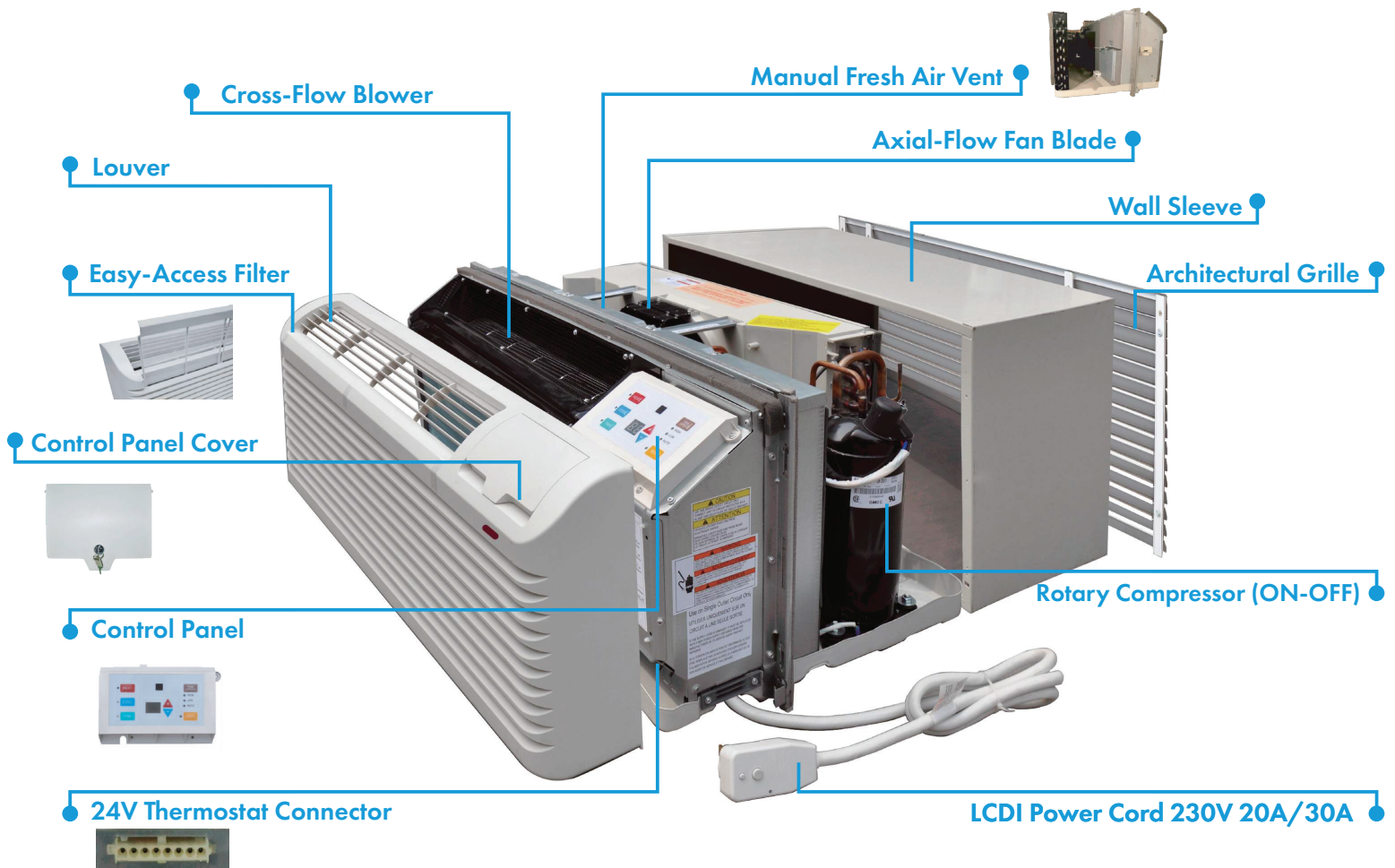

# PTAC KEY COMPONENTS



The manufacturer reserves the right to make changes to the design, colour and specifications of the product shown. All images are for illustrative purposes only and some features such as grilles are optional accessories and not considered as standard equipment.

# SPTAC KEY COMPONENTS

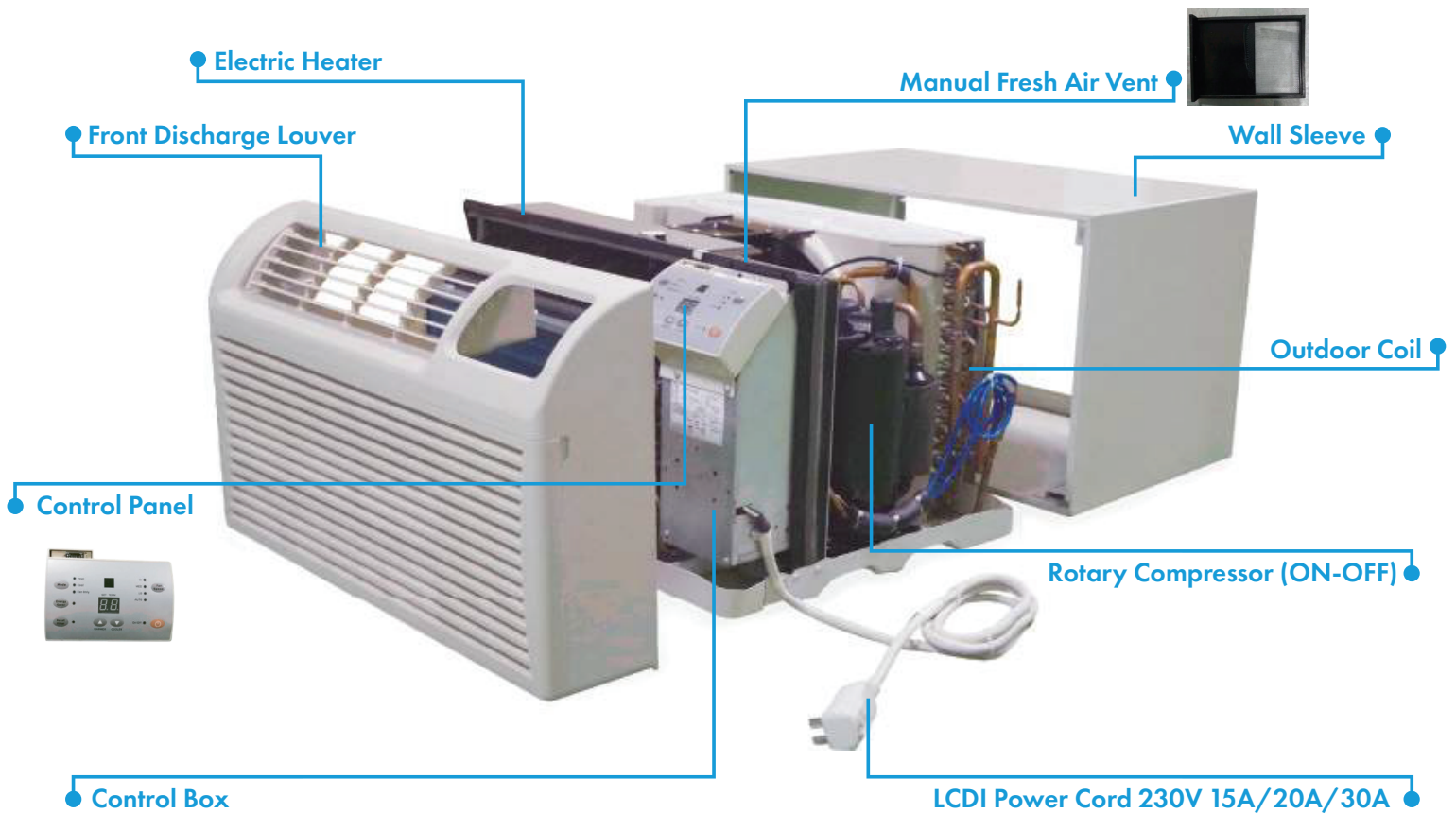

The manufacturer reserves the right to make changes to the design, colour and specifications of the product shown. All images are for illustrative purposes only and some features such as grilles are optional accessories and not considered as standard equipment.

# UNIT DIMENSIONAL DRAWINGS

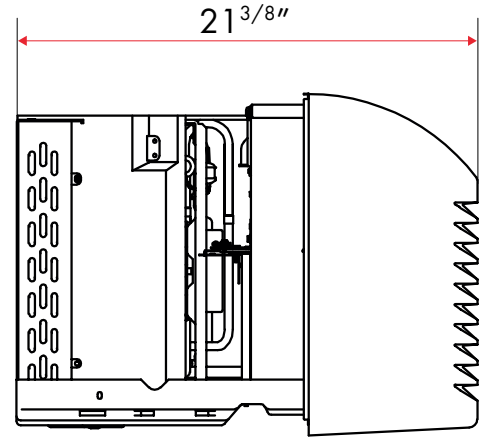
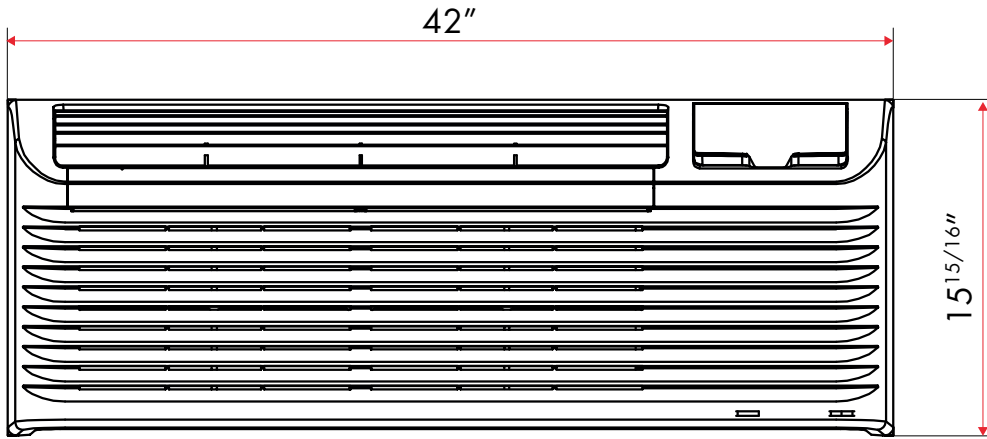

## NET DIMENSIONS WITH WALL SLEEVE (WxDxH)

42" x 21<sup>5/8</sup>" x 16<sup>1/16</sup>" [1066 x 549 x 408 mm]

## NET DIMENSIONS WITHOUT WALL SLEEVE (WxDxH)

42" x 21<sup>3/8</sup>" x 15<sup>15/16</sup>" [1066 x 543 x 405 mm]

## NET DIMENSIONS PACKED UNIT (WxDxH)

45<sup>1/4</sup>" x 24<sup>13/16</sup>" x 18<sup>7/8</sup>" [1150 x 630 x 480 mm]

# WALL SLEEVE DIMENSIONAL DRAWINGS

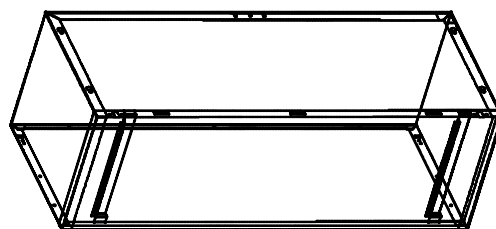
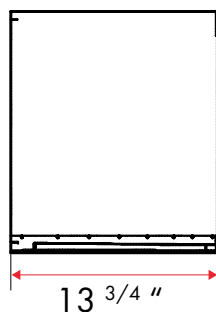
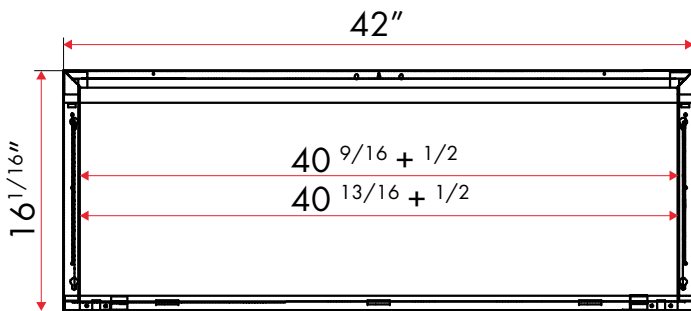

The manufacturer reserves the right to make changes to the design, colour and specifications of the product shown. All images are for illustrative purposes only and some features such as grilles are optional accessories and not considered as standard equipment.

# GRILLES DIMENSIONAL DRAWINGS

## STANDARD OUTDOOR GRILLE

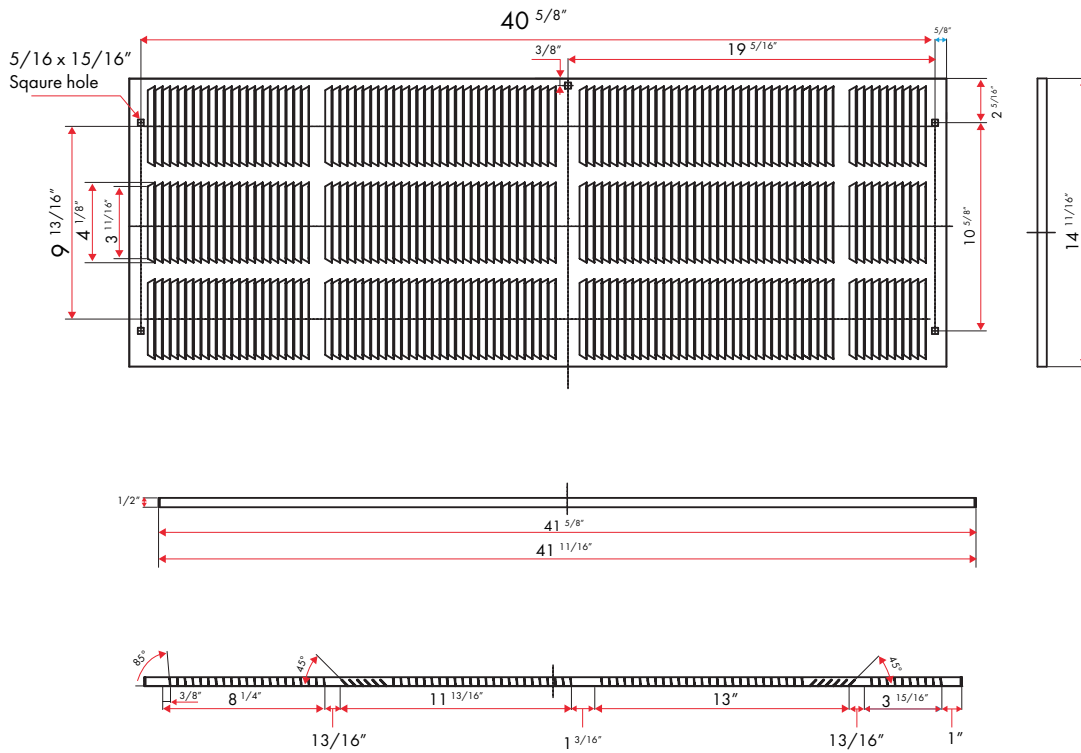

## ARCHITECTURAL OUTDOOR GRILLE (OPTIONAL)

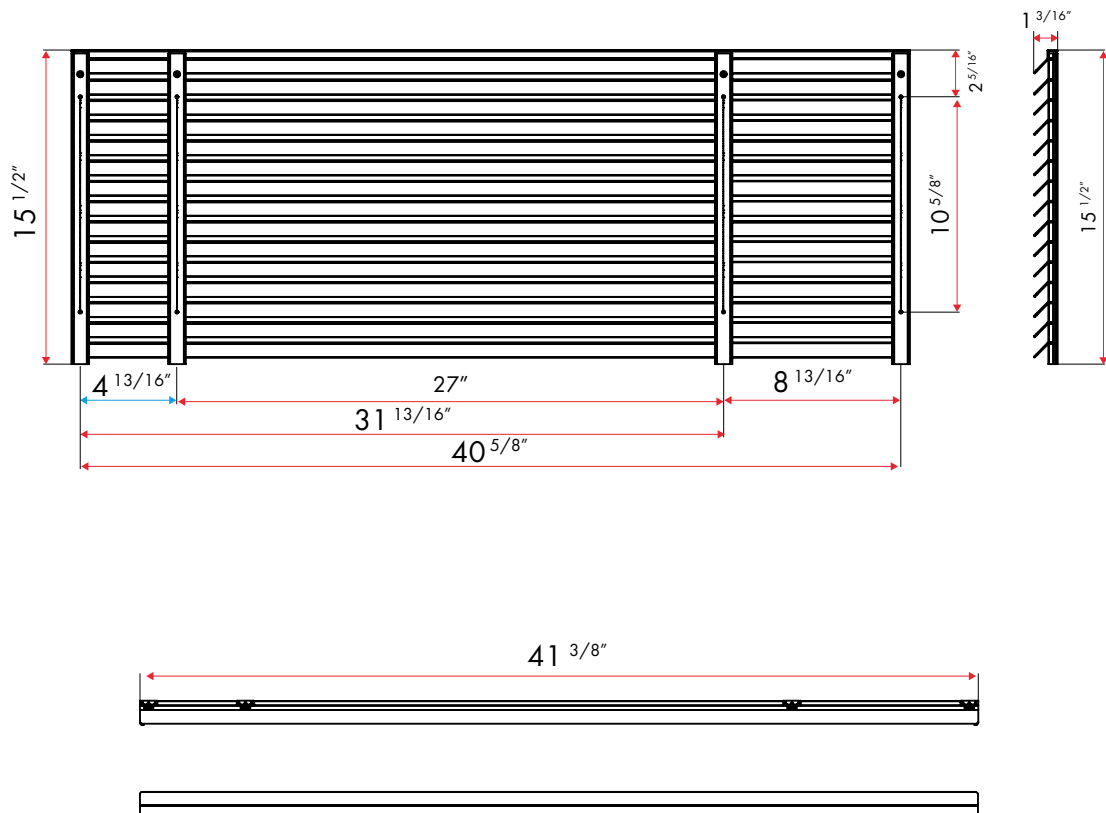

# PTAC STANDARD FEATURES

## HIGH ENERGY EFFICIENCIES

Efficient design with EER as high as 13.0 and COP of 3.55. Exceeds current AHRI standards and DOE requirements.

## OUTLET DESIGN

Optimized air discharge configurations with large axial blower wheels and lower blower speeds resulting in lower sound levels in occupied spaces.

## COMPRESSOR AND EVAPORATOR FREEZE PROTECTION

Temperature sensors are used to detect if the compressor or evaporator is too cold and then signal to stop the operation of the unit.

## SELF-DIAGNOSTIC

Unit will perform self-diagnostics and display appropriate error code.

## RAPID HEAT MODE

When in Rapid Heat Mode electric heat will be engaged to raise the room temperature quickly. When room temperature is met, the unit will revert to standard heat pump mode.

## FACTORY TESTED

All units are thoroughly tested before shipping to ensure proper functionality.

## EASY INSTALLATION AND MAINTENANCE

Cover is one piece including discharge grille and louvers. PCB is in enclosed electrical box and outdoor components are within molded enclosure. MERV3 filters are easily accessed for cleaning and replacement.

## TWO-STAGE ELECTRIC HEATER

Electric heaters are available in various sizes.

## USER FRIENDLY CONTROLLER

Standard control panel, compatible with remote controller and wired wall thermostat.

## DUAL FAN MOTORS

All PTAC units have two fan motors with quiet operation and maximum efficiency. Motors are permanently lubricated to reduce maintenance and totally enclosed to keep dirt and water out of the motor windings.

## QUIET AND ENERGY EFFICIENT COMPRESSOR

Smooth operation for quiet, dependable service and high efficiency.

## SUPERIOR TEMPERATURE CONTROL

Microprocessor controls are programmed to interface with the temperature sensors to maximize comfort conditions for the room occupant and provide outstanding features.

## OPERATION MEMORY RESTART AFTER POWER FAILURE

The unit setting before any power outage will be memorized and resume after power supply restarts.

## FRONT DESK CONTROL

The PTAC unit can be turned ON or OFF by front desk control before the occupant enters into the room or after leaving the room.

## CONTINUOUS FRESH AIR INTAKE

Fresh air is drawn into the PTAC unit through a manually set fresh air vent.

# PTAC ACCESSORIES

## 18 GAUGE INSULATED WALL SLEEVE

- Industry standard dimensions of 42" wide x 16" high x 14" deep.
- Sleeves may be shipped folded for more efficient packing.
- Upon request, wall sleeves can be provided with or without foam insulation.

## OUTDOOR GRILLES

- Stamped aluminum grille to attach to wall sleeve.
- Silver aluminum architectural grille with a minimum size of 42" wide x 15.5" high.

## PANEL COVER LOCK

- Panel cover with lock to ensure safety and security.

## CONDENSATE DRAINAGE HOSE KIT

- Can be attached to the wall sleeve drain pan for the disposal of condensate water.

## OPTIONAL CONTROLLERS

- To use in conjunction with the standard control panel on the unit.

## LEVELING LEGS

- Heavy gauge steel, black, leveling legs with adjustable height of 3<sup>1/4</sup>" to 5<sup>1/2</sup>" from finished floor. Easy to mount and secure to standard wall sleeve.

## ELECTRICAL SUBBASE KIT

- Easy to mount and secure to standard wall sleeve, with adjustable height of 3<sup>1/4</sup>" to 5<sup>1/2</sup>" from finished floor.
- Contains a pre-wired NEMA receptacle outlet, with multiple electrical knockouts for fast and easy installation.
- Decorative side skirting for finished appearance as well as an optional pre-wired disconnect switch and fuse kits (on-site installation required) .

## NON-ELECTRICAL SUBBASE KIT

- Easy to mount and secure to standard wall sleeve, with adjustable height of 3<sup>1/4</sup>" to 5<sup>1/2</sup>" from finished floor.
- With decorative side skirting for finished appearance.
- Dimensions are 42" long x 1<sup>1/2</sup>" deep x 3<sup>1/4</sup>" high.

The manufacturer reserves the right to make changes to the design, colour and specifications of the product shown. All images are for illustrative purposes only and some features such as grilles are optional accessories and not considered as standard equipment.

# PTAC PRODUCT SPECIFICATIONS

## STANDARD MODELS

### COOLING WITH ELECTRIC HEATER

PTAC-CEH-[SIZE]			07-X	09-X	12-X	15-X
POWER SUPPLY		V/Ph/Hz	208-230 / 1 / 60			
COOLING	CAPACITY	BTU/H	6800/7200	9300/9500	11800/12000	14300/14500
	EER	BTU/w.h	11.9/11.9	11.7/11.4	10.7/10.5	10.2/10.2
	POWER INPUT	W	570/605	795/835	1100/1140	1400/1420
	RATED CURRENT	A	2.8/2.7	3.9/3.7	5.4/5.1	6.8/6.3
ELECTRIC HEATER		kW	230V 3kW			230V 5 kW
POWER CABLE SPECIFICATION		A	240V / 20A			240V / 30A
MAXIMUM INPUT POWER		W	740	1040	1460	1760
MAXIMUM CURRENT		A	3.9	5.1	7.3	8.9
OPERATION CONTROL (OPTIONAL)			Remote controller, wired controller, 24V thermostat or external controller			
INDOOR FAN MOTOR	INPUT	W	55		64	
	CAPACITOR	uF	1.5			
	SPEED (H/L)	RPM	750/650		1050/850	
INDOOR AIR FLOW (H/L)		CFM	410/365		470/410	
INDOOR NOISE LEVEL (H/L)		dB(A)	46/36		48/42	
COMPRESSOR	Type		Rotary			
	CAPACITOR	uF	15	25		40
OUTDOOR FAN MOTOR	INPUT	W	95			100
	CAPACITOR	uF	3			
	SPEED	RPM	1600		1680	
OUTDOOR NOISE LEVEL		dB(A)	67			
REFRIGERANT	TYPE		R410A			
	CHARGE	OZ	30	33	31	35
RECOMMENDED OPERATION TEMPERATURE RANGE		°F	60-90			
RECOMMENDED AMBIENT TEMPERATURE RANGE			50-115			
APPLICATION AREA		FT <sup>2</sup>	<107	107-193		193-269
NET DIMENSIONS (W x H x D)		IN	42 x 15 15/16 x 21 3/8			
PACKING DIMENSIONS (W x H x D)			45 1/4 x 18 7/8 x 24 13/16			
UNIT WEIGHT	NET	LBS	97	100	108	110
	SHIP		110	114	121	123
LOADING QUANTITY (20' / 40' / 40' HQ)		UNITS	72 / 152 / 190			

(ALL DIMENSIONS ARE APPROXIMATE WITHIN 1/16 OF AN INCH OF THOSE INDICATED)

The manufacturer reserves the right to make changes to the design, colour and specifications of the product shown. All images are for illustrative purposes only and some features such as grilles are optional accessories and not considered as standard equipment.



The manufacturer reserves the right to make changes to the design, colour and specifications of the product shown. All images are for illustrative purposes only and some features such as grilles are optional accessories and not considered as standard equipment.

PTAC-CEH-[SIZE]			07-Z	09-Z	12-Z	15-Z
POWER SUPPLY		V/Ph/Hz	265 / 1 / 60			
COOLING	CAPACITY	BTU/H	7000	9200	12000	15000
	EER	BTU/w.h	12.1	11.5	10.6	10.1
	POWER INPUT	W	580	800	1130	1485
	RATED CURRENT	A	2.3	3.3	4.5	5.7
ELECTRIC HEATER		kW	3			5
POWER CABLE SPECIFICATION		A	277V / 20 A			277V / 30A
MAXIMUM INPUT POWER		W	770	995	1400	1745
MAXIMUM CURRENT		A	2.9	3.9	5	7
OPERATION CONTROL (OPTIONAL)			Remote controller, wired controller, 24V thermostat or external controller			
INDOOR FAN MOTOR	INPUT	W	55		56	
	CAPACITOR	µF	1.2		1	
	SPEED (H/L)	RPM	940/740		970/800	
INDOOR AIR FLOW (H/L)		CFM	383/259		400/312	
INDOOR NOISE LEVEL (H/L)		dB(A)	45/36		47/40	
COMPRESSOR	TYPE		Rotary			
	CAPACITOR	µF	15	25	30	25
OUTDOOR FAN MOTOR	INPUT	W	95		100	
	CAPACITOR	µF	2			
	SPEED	RPM	1600		1640	
OUTDOOR NOISE LEVEL		dB(A)	66		67	68
REFRIGERANT	TYPE		R410A			
	CHARGE	OZ	30	31	30	34
RECOMMENDED OPERATION TEMPERATURE RANGE		°F	60-90			
RECOMMENDED AMBIENT TEMPERATURE RANGE			50-115			
APPLICATION AREA		FT <sup>2</sup>	108-140	145-194	189-252	236-312
NET DIMENSIONS (W x H x D)		IN	42 x 15 15/16 x 21 3/8			
PACKING DIMENSIONS (W x H x D)			45 1/4 x 18 7/8 x 24 13/16			
UNIT WEIGHT	NET	LBS	97	106	108	117
	SHIP		110	119	121	128
LOADING QUANTITY (20' / 40' / 40' HQ)		UNITS	72 / 152 / 190			

(ALL DIMENSIONS ARE APPROXIMATE WITHIN 1/16 OF AN INCH OF THOSE INDICATED)

# STANDARD MODELS

## HEAT PUMP WITH ELECTRIC HEATER

PTAC-HEH-[SIZE]			07-X	09-X	12-X	15-X
POWER SUPPLY		V/Ph/Hz	208-230 / 1 / 60			
COOLING	CAPACITY	BTU/H	6800/7200	9300/9500	11800/12000	14300/14500
	EER	BTU/w.h	11.9/11.9	11.7/11.4	10.7/10.5	10.2/10.2
	POWER INPUT	W	570/605	795/835	1100/1140	1400/1420
	RATED CURRENT	A	2.8/2.7	3.9/3.7	5.4/5.1	6.8/6.3
HEATING	CAPACITY	BTU/H	6100/6400	8300/8500	10800/11000	13200/13600
	COP	W/W	3.34/3.35	3.55/3.51	3.51/3.39	3.35/3.38
	POWER INPUT	W	535/560	685/710	900/950	1155/1180
	RATED CURRENT	A	2.6/2.5	3.3/3.1	4.5/4.2	5.6/5.2
ELECTRIC HEATER		kW	230V 3kW			230V 5 kW
POWER CABLE SPECIFICATION		A	240V / 20A			240V / 30A
MAXIMUM INPUT POWER		W	740	1040	1460	1760
MAXIMUM CURRENT		A	3.9	5.1	7.3	8.9
OPERATION CONTROL (OPTIONAL)			Remote controller, wired controller, 24V thermostat or external controller			
INDOOR FAN MOTOR	INPUT	W	55		64	
	CAPACITOR	uF	1.5			
	SPEED (H/L)	RPM	750/650		1050/850	
INDOOR AIR FLOW (H/L)		CFM	410/365		470/410	
INDOOR NOISE LEVEL (H/L)		dB(A)	46/36		48/42	
COMPRESSOR	TYPE		Rotary			
	CAPACITOR	uF	15	25		40
OUTDOOR FAN MOTOR	INPUT	W	95			100
	CAPACITOR	uF	3			
	SPEED	RPM	1600		1680	
OUTDOOR NOISE LEVEL		dB(A)	67			
REFRIGERANT	TYPE		R410A			
	CHARGE	OZ	30	33	31	35
RECOMMENDED OPERATION TEMPERATURE RANGE		°F	60-90			
RECOMMENDED AMBIENT TEMPERATURE RANGE			50-115			
APPLICATION AREA		FT <sup>2</sup>	<107	107-193		193-269
NET DIMENSIONS (W x H x D)		IN	42 x 15 15/16 x 21 3/8			
PACKING DIMENSIONS (W x H x D)			45 1/4 x 18 7/8 x 24 13/16			
UNIT WEIGHT	NET	LBS	97	100	108	110
	SHIP		110	114	121	123
LOADING QUANTITY (20' / 40' / 40' HQ)		UNITS	72 / 152 / 190			

(ALL DIMENSIONS ARE APPROXIMATE WITHIN 1/16 OF AN INCH OF THOSE INDICATED)

The manufacturer reserves the right to make changes to the design, colour and specifications of the product shown. All images are for illustrative purposes only and some features such as grilles are optional accessories and not considered as standard equipment.

The manufacturer reserves the right to make changes to the design, colour and specifications of the product shown. All images are for illustrative purposes only and some features such as grilles are optional accessories and not considered as standard equipment.

PTAC-HEH-[SIZE]			07-Z	09-Z	12-Z	15-Z
POWER SUPPLY		V/Ph/Hz	265 / 1 / 60			
COOLING	CAPACITY	BTU/H	7000	9200	12000	15000
	EER	BTU/w.h	12.1	11.5	10.6	10.1
	POWER INPUT	W	580	800	1130	1485
	RATED CURRENT	A	2.3	3.3	4.5	5.7
HEATING	CAPACITY	BTU/H	6100	8500	11400	14000
	COP	W/W	3.40	3.51	3.34	3.16
	POWER INPUT	W	525	710	1000	1300
	RATED CURRENT	A	2.1	2.9	3.9	4.9
ELECTRIC HEATER		kW	3			5
POWER CABLE SPECIFICATION		A	277V / 20 A			277V / 30A
MAXIMUM INPUT POWER		W	770	995	1400	1745
MAXIMUM CURRENT		A	2.9	3.9	5	7
OPERATION CONTROL (OPTIONAL)			Remote controller, wired controller, 24V thermostat or external controller			
INDOOR FAN MOTOR	INPUT	W	55		56	
	CAPACITOR	uF	1.2		1	
	SPEED (H/L)	RPM	940/740		970/800	
INDOOR AIR FLOW (H/L)		CFM	383/259		400/312	
INDOOR NOISE LEVEL (H/L)		dB(A)	45/36		47/40	
COMPRESSOR	TYPE		Rotary			
	CAPACITOR	F	15	25	30	25
OUTDOOR FAN MOTOR	INPUT	W	95		100	
	CAPACITOR	uF	2			
	SPEED	RPM	1600		1640	
OUTDOOR NOISE LEVEL		dB(A)	66		67	68
REFRIGERANT	TYPE		R410A			
	CHARGE	OZ	30	31	30	34
RECOMMENDED OPERATION TEMPERATURE RANGE		°F	60-90			
RECOMMENDED AMBIENT TEMPERATURE RANGE			50-115			
APPLICATION AREA		FT <sup>2</sup>	108-140	145-194	189-252	236-312
NET DIMENSIONS (W x H x D)		IN	42 x 15 15/16 x 21 3/8			
PACKING DIMENSIONS (W x H x D)			45 1/4 x 18 7/8 x 24 13/16			
UNIT WEIGHT	NET	LBS	99	108	110	119
	SHIP		112	121	123	130
LOADING QUANTITY (20' / 40' / 40' HQ)		UNITS	72/152/190			

(ALL DIMENSIONS ARE APPROXIMATE WITHIN 1/16 OF AN INCH OF THOSE INDICATED)

# iPTAC HIGH EFFICIENCY MODELS

## COOLING WITH ELECTRIC HEATER

iPTAC-CEH-[SIZE]			07-X	09-X	12-X	15-X
POWER SUPPLY		V/Ph/Hz	208-230 / 1 / 60			
COOLING	CAPACITY	BTU/H	6800/7200	9300/9500	12280/12750	14300/14500
	EER	BTU/w.h	13/12.8	12.1/12.1	11.7/11.7	10.6/10.6
	DOE MINIMUM EER		11.96/11.84	11.21/11.15	10.32/10.18	9.71/9.65
	POWER INPUT	W	520/560	765/785	1050/1090	1345/1365
	RATED CURRENT	A	2.6/2.5	3.8/3.6	5.3/4.9	6.3/5.9
ELECTRIC HEATER		kW	230V 3kW			230V 5 kW
POWER CABLE SPECIFICATION		A	240V / 20A			240V / 30A
MAXIMUM INPUT POWER		W	740	1040	1460	1760
MAXIMUM CURRENT		A	3.9	5.1	7.3	8.9
OPERATION CONTROL (OPTIONAL)			Remote controller, wired controller, 24V thermostat or external controller			
INDOOR FAN MOTOR	INPUT	W	55		64	
	CAPACITOR	uF	1.5			
	SPEED (H/L)	RPM	750/650		1050/850	
INDOOR AIR FLOW (H/L)		CFM	410/365		470/410	
INDOOR NOISE LEVEL (H/L)		dB(A)	46/36		48/42	
COMPRESSOR	TYPE		Rotary			
	CAPACITOR	uF	15	20	40	
OUTDOOR FAN MOTOR	INPUT	W	95			100
	CAPACITOR	uF	3			
	SPEED	RPM	1600			1680
OUTDOOR NOISE LEVEL		dB(A)	67			
REFRIGERANT	TYPE		R410A			
	CHARGE	OZ	30	33	31	35
RECOMMENDED OPERATION TEMPERATURE RANGE		°F	60-90			
RECOMMENDED AMBIENT TEMPERATURE RANGE			50-115			
APPLICATION AREA		FT <sup>2</sup>	<107	107-193		193-269
NET DIMENSIONS (W x H x D)		IN	42 x 15 15/16 x 21 3/8			
PACKING DIMENSIONS (W x H x D)			45 1/4 x 18 7/8 x 24 13/16			
UNIT WEIGHT	NET	LBS	97	100	108	110
	SHIP		110	114	121	123
LOADING QUANTITY (20' / 40' / 40' HQ)		UNITS	72 / 152 / 190			

(ALL DIMENSIONS ARE APPROXIMATE WITHIN 1/16 OF AN INCH OF THOSE INDICATED)

The manufacturer reserves the right to make changes to the design, colour and specifications of the product shown. All images are for illustrative purposes only and some features such as grilles are optional accessories and not considered as standard equipment.

The manufacturer reserves the right to make changes to the design, colour and specifications of the product shown. All images are for illustrative purposes only and some features such as grilles are optional accessories and not considered as standard equipment.

IPTAC-CEH-[SIZE]			07-Z	09-Z	12-Z	15-Z	
POWER SUPPLY		V/Ph/Hz	265 / 1 / 60				
COOLING	CAPACITY	BTU/H	7200	9500	12500	15000	
	EER	BTU/w.h	12.3	12.1	11.7	10.4	
	DOE MINIMUM EER			11.84	11.15	10.25	9.5
	POWER INPUT	W	585	785	1065	1435	
	RATED CURRENT	A	2.3	3.0	4.1	5.4	
ELECTRIC HEATER		kW	3			5	
POWER CABLE SPECIFICATION		A	277V / 20A			277V / 30A	
MAXIMUM INPUT POWER		W	770	995	1400	1745	
MAXIMUM CURRENT		A	2.9	3.9	5	7	
OPERATION CONTROL (OPTIONAL)			Remote controller, wired controller, 24V thermostat or external controller				
INDOOR FAN MOTOR	INPUT	W	55		56		
	CAPACITOR	µF	1.2		1		
	SPEED (H/L)	RPM	940/740		970/800		
INDOOR AIR FLOW (H/L)		CFM	383/259		400/312		
INDOOR NOISE LEVEL (H/L)		dB(A)	45/36		47/40		
COMPRESSOR	TYPE		Rotary				
	CAPACITOR	µF	15	25	30	25	
OUTDOOR FAN MOTOR	INPUT	W	95		100		
	CAPACITOR	µF	2				
	SPEED	RPM	1600		1640		
OUTDOOR NOISE LEVEL		dB(A)	66		67	68	
REFRIGERANT	TYPE		R410A				
	CHARGE	OZ	30	31	30	34	
RECOMMENDED OPERATION TEMPERATURE RANGE		°F	60-90				
RECOMMENDED AMBIENT TEMPERATURE RANGE			50-115				
APPLICATION AREA		FT <sup>2</sup>	113-150	150-201	198-264	236-312	
NET DIMENSIONS (W x H x D)		IN	42 x 15 15/16 x 21 3/8				
PACKING DIMENSIONS (W x H x D)			45 1/4 x 18 7/8 x 24 13/16				
UNIT WEIGHT	NET	LBS	97	106	108	117	
	SHIP		110	119	121	128	
LOADING QUANTITY (20' / 40' / 40' HQ)		UNITS	72 / 152 / 190				

(ALL DIMENSIONS ARE APPROXIMATE WITHIN 1/16 OF AN INCH OF THOSE INDICATED)

# iPTAC HIGH EFFICIENCY MODELS

## HEAT PUMP WITH ELECTRIC HEATER

iPTAC-HEH-[SIZE]			07-X	09-X	12-X	15-X
POWER SUPPLY		V/Ph/Hz	208-230 / 1 / 60			
COOLING	CAPACITY	BTU/H	6800/7200	9300/9500	12280/12750	14300/14500
	EER	BTU/w.h	13/12.8	12.1/12.1	11.7/11.7	10.6/10.6
	POWER INPUT	W	520/560	765/785	1050/1090	1345/1365
	RATED CURRENT	A	2.6/2.5	3.8/3.6	5.3/4.9	6.3/5.9
HEATING	CAPACITY	BTU/H	6300/6400	8300/8500	11000/11400	13200/13600
	COP	W/W	3.55/3.54	3.55/3.51	3.52/3.51	3.36/3.38
	POWER INPUT	W	520/530	685/710	915/950	1150/1180
	RATED CURRENT	A	2.5/2.3	3.3/3.1	4.7/4.4	5.6/5.2
ELECTRIC HEATER		kW	230V 3kW			230V 5 kW
POWER CABLE SPECIFICATION		A	240V / 20A			240V / 30A
MAXIMUM INPUT POWER		W	740	1040	1460	1760
MAXIMUM CURRENT		A	3.9	5.1	7.3	8.9
OPERATION CONTROL (OPTIONAL)			Remote controller, wired controller, 24V thermostat or external controller			
INDOOR FAN MOTOR	INPUT	W	55		64	
	CAPACITOR	uF	1.5			
	SPEED (H/L)	RPM	750/650		1050/850	
INDOOR AIR FLOW (H/L)		CFM	410/365		470/410	
INDOOR NOISE LEVEL (H/L)		dB(A)	46/36		48/42	
COMPRESSOR	TYPE		Rotary			
	CAPACITOR	uF	15	20	40	
OUTDOOR FAN MOTOR	INPUT	W	95			100
	CAPACITOR	uF	3			
	SPEED	RPM	1600			1680
OUTDOOR NOISE LEVEL		dB(A)	67			
REFRIGERANT	TYPE		R410A			
	CHARGE	OZ	30	33	31	35
RECOMMENDED OPERATION TEMPERATURE RANGE		°F	60-90			
RECOMMENDED AMBIENT TEMPERATURE RANGE			50-115			
APPLICATION AREA		FT <sup>2</sup>	<107	107-193		193-269
NET DIMENSIONS (W x H x D)		IN	42 x 15 15/16 x 21 3/8			
PACKING DIMENSIONS (W x H x D)			45 1/4 x 18 7/8 x 24 13/16			
UNIT WEIGHT	NET	LBS	97	100	108	110
	SHIP		110	114	121	123
LOADING QUANTITY (20' / 40' / 40' HQ)		UNITS	72 / 152 / 190			

(ALL DIMENSIONS ARE APPROXIMATE WITHIN 1/16 OF AN INCH OF THOSE INDICATED)

The manufacturer reserves the right to make changes to the design, colour and specifications of the product shown. All images are for illustrative purposes only and some features such as grilles are optional accessories and not considered as standard equipment.

iPTAC-HEH-[SIZE]			07-Z	09-Z	12-Z	15-Z
POWER SUPPLY		V/Ph/Hz	265 / 1 / 60			
COOLING	CAPACITY	BTU/H	7200	9500	12500	15000
	EER	BTU/w.h	12.3	12.1	11.7	10.4
	POWER INPUT	W	585	785	1065	1435
	RATED CURRENT	A	2.3	3.0	4.1	5.4
HEATING	CAPACITY	BTU/H	6100	8500	11400	14000
	COP	W/W	3.44	3.51	3.40	3.16
	POWER INPUT	W	520	710	980	1300
	RATED CURRENT	A	1.9	2.7	3.7	4.9
ELECTRIC HEATER		kW	3			5
POWER CABLE SPECIFICATION		A	277V / 20A			277V / 30A
MAXIMUM INPUT POWER		W	770	995	1400	1745
MAXIMUM CURRENT		A	2.9	3.9	5	7
OPERATION CONTROL (OPTIONAL)			Remote controller, wired controller, 24V thermostat or external controller			
INDOOR FAN MOTOR	INPUT	W	55		56	
	CAPACITOR	µF	1.2		1	
	SPEED (H/L)	RPM	940/740		970/800	
INDOOR AIR FLOW (H/L)		CFM	383/259		400/312	
INDOOR NOISE LEVEL (H/L)		dB(A)	45/36		47/40	
COMPRESSOR	TYPE		Rotary			
	CAPACITOR	µF	15	25	30	25
OUTDOOR FAN MOTOR	INPUT	W	95		100	
	CAPACITOR	µF	2			
	SPEED	RPM	1600		1640	
OUTDOOR NOISE LEVEL		dB(A)	66		67	68
REFRIGERANT	TYPE		R410A			
	CHARGE	OZ	30	31	30	34
RECOMMENDED OPERATION TEMPERATURE RANGE		°F	60-90			
RECOMMENDED AMBIENT TEMPERATURE RANGE			50-115			
APPLICATION AREA		FT <sup>2</sup>	113-150	150-201	198-264	236-312
NET DIMENSIONS (W x H x D)		IN	42 x 15 15/16 x 21 3/8			
PACKING DIMENSIONS (W x H x D)			45 1/4 x 18 7/8 x 24 13/16			
UNIT WEIGHT	NET	LBS	99	108	110	119
	SHIP		112	121	123	130
LOADING QUANTITY (20' / 40' / 40' HQ)		UNITS	72 / 152 / 190			

(ALL DIMENSIONS ARE APPROXIMATE WITHIN 1/16 OF AN INCH OF THOSE INDICATED)

# SPTAC STANDARD FEATURES

## HIGH ENERGY EFFICIENCIES

Units meet or exceed current DOE energy efficiency requirements.

## COMPACT DESIGN

Standard 26" wide x 15<sup>9/16</sup>" high x 21<sup>9/16</sup>" deep overall size to accommodate industry standard wall sleeves.

## COMBINED PANEL AND BI-DIRECTIONAL AIR ADJUSTMENT

Newly designed front panel allows easy access to the air filter and control panel. Furthermore, the front louver can be adjusted to vertically discharge.

## SELF-DIAGNOSTIC

Unit will perform self-diagnostics and display appropriate error code which will be shown on LED display.

## RAPID HEAT MODE

When in Rapid Heat Mode electric heat will be engaged to raise the room temperature quickly. When room temperature is met, the unit will revert to standard heat pump mode.

## QUIET OPERATION

The indoor fan operates quietly with three speeds to choose from. The outdoor fan operates with two speeds. The compressor is acoustically isolated to minimize sound transmittance to the occupied space. Sleep mode allows the fan to operate at low speed while delivering comfort and energy savings.

## OPTIMIZED OUTDOOR FAN OPERATION

While in cooling mode, the outdoor axial blower will direct condensate across the face of the condenser coil, resulting in increased operating efficiency.

## EASY INSTALLATION AND MAINTENANCE

Filters are easily accessed for cleaning.

## USER-FRIENDLY CONTROLLER

The standard onboard control panel is compatible with the remote controller, as shown below.

## ENERGY SAVER MODE (AUTO FAN)

When auto fan mode is selected, the unit will automatically choose the optimal running speed for energy saving.

## FAN CYCLE SWITCH

When the unit is ON the fan will run continuously. In auto mode, the fan will be turned on or off according to the operating status of compressor and electric heater.

## DUAL FAN MOTORS

All SPTAC units have two fan motors with quiet operation and maximum efficiency. Motors are permanently lubricated to reduce maintenance and totally enclosed to keep dirt and water out of the motor windings.

## SLIDE OUT CHASSIS

Chassis can slide in and out of the wall sleeve for ease of installation or maintenance.

## OPERATION MEMORY RESTART AFTER POWER FAILURE

The unit setting before any power outage will be memorized and resume after power supply restarts.

## CONTINUOUS FRESH AIR INTAKE

Fresh air is drawn into the SPTAC unit through a manually set fresh air vent.



# SPTAC ACCESSORIES

## INSULATED WALL SLEEVE

- Industry standard dimensions of 26" width x 15<sup>3</sup>/<sub>4</sub>" height x 16<sup>13</sup>/<sub>16</sub>" depth.
- Sleeves may be shipped folded for more efficient packing.
- Upon request, wall sleeves can be provided with or without foam insulation.

## OUTDOOR GRILLES

- Stamped aluminum grille to attach to wall sleeve.

## OPTIONAL CONTROLLER

- To use additionally to the standard control panel on the unit.

The manufacturer reserves the right to make changes to the design, colour and specifications of the product shown. All images are for illustrative purposes only and some features such as grilles are optional accessories and not considered as standard equipment.

# SPTAC PRODUCT SPECIFICATIONS

## COOLING WITH ELECTRIC HEATER

SPTAC-CEH-[SIZE]			09-X	12-X
POWER SUPPLY		V/Ph/Hz	208-230 / 1 / 60	
COOLING	CAPACITY	BTU/H	9400/9300	11800/116000
	EER	BTU/w.h	10.0/10.2	10.0/10.1
	POWER INPUT	W	940/910	1185/1145
	RATED CURRENT	A	4.1/4.4	5.2/5.6
ELECTRIC HEATER		kW	230V 3.4kW	
INDOOR AIR FLOW (H)		CFM	271	
INDOOR NOISE LEVEL (H)		dB(A)	60	
COMPRESSOR	TYPE		Rotary	
REFRIGERANT	TYPE		R410A	
	CHARGE	OZ	20	21
RECOMMENDED OPERATION TEMPERATURE RANGE		°F	60-90	
RECOMMENDED AMBIENT TEMPERATURE RANGE			50-115	
NET DIMENSIONS (W x H x D)		IN	26 x 15 9/16 x 21 9/16	
PACKING DIMENSIONS (W x H x D)			30 1/8 x 18 7/8 x 24 13/16	
UNIT WEIGHT	NET	LBS	83	84
	SHIP		93	94
LOADING QUANTITY (20' / 40' / 40' HQ)		UNITS	108 / 216 / 285	

## COOLING ONLY

SPTAC-CO-[SIZE]			09-X	12-X	09-Y	12-Y
POWER SUPPLY		V/Ph/Hz	208-230 / 1 / 60		115 / 1 / 60	
COOLING	CAPACITY	BTU/H	9400/9300	11800/11600	9000	11800
	EER	BTU/w.h	10.0/10.2	10.0/10.1	9.8	9.8
	POWER INPUT	W	940/910	1185/1145	920	1200
	RATED CURRENT	A	4.1/4.4	5.2/5.6	8.1	10.6
INDOOR AIR FLOW (H)		CFM	271		288	
INDOOR NOISE LEVEL (H/L)		dB(A)	60		59	
COMPRESSOR	TYPE		Rotary			
REFRIGERANT	TYPE		R410A			
	CHARGE	OZ	20	21	19	29
RECOMMENDED OPERATION TEMPERATURE RANGE		°F	60-90			
RECOMMENDED AMBIENT TEMPERATURE RANGE			50-115			
NET DIMENSIONS (W x H x D)		IN	26 x 15 9/16 x 21 9/16			
PACKING DIMENSIONS (W x H x D)			30 1/8 x 18 7/8 x 24 13/16			
UNIT WEIGHT	NET	LBS	80	82	80	84
	SHIP		90	91	90	94
LOADING QUANTITY (20' / 40' / 40' HQ)		UNITS	108 / 216 / 285			

(ALL DIMENSIONS ARE APPROXIMATE WITHIN 1/16 OF AN INCH OF THOSE INDICATED)

## HEAT PUMP WITH ELECTRIC HEATER

SPTAC-HEH-[SIZE]			07-X	09-X	12-X	09-Y
POWER SUPPLY		V/Ph/Hz	208-230 / 1 / 60			115 / 1 / 60
COOLING	CAPACITY	BTU/H	7400/7200	9300/9100	11700/11500	9000
	EER	BTU/w.h	10.3/10.6	9.9/10.0	9.6/9.6	9.8
	POWER INPUT	W	720/680	940/910	1220/1200	920
	RATED CURRENT	A	3.2/3.4	4.1/4.4	5.6/6.1	8.1
HEATING	CAPACITY	BTU/H	6800/6600	8800/8600	11400/11200	8500
	COP	W/W	3.1/3.1	3.1/3.1	2.9/2.9	3.1
	POWER INPUT	W	640/620	830/810	1160/1140	805
	RATED CURRENT	A	2.8/3.0	3.6/3.9	5.4/5.9	7.1
ELECTRIC HEATER		kW	230V 3.4kW			115V 1.2kW
INDOOR AIR FLOW (H)		CFM	271			271
INDOOR NOISE LEVEL (H)		dB(A)	60			59
COMPRESSOR	TYPE		Rotary			
REFRIGERANT	TYPE		R410A			
	CHARGE	OZ	18	20	32	19
RECOMMENDED OPERATION TEMPERATURE RANGE		°F	60-90			
RECOMMENDED AMBIENT TEMPERATURE RANGE			50-115			
NET DIMENSIONS (W X H X D)		IN.	26 x 15 9/16 x 21 9/16			
PACKING DIMENSIONS (W X H X D)			30 1/8 x 18 7/8 x 24 13/16			
UNIT WEIGHT	NET	LBS	84	84	97	84
	SHIP		94	94	110	94
LOADING QUANTITY (20' / 40' / 40' HQ)		UNITS	108 / 216 / 285			

(ALL DIMENSIONS ARE APPROXIMATE WITHIN 1/16 OF AN INCH OF THOSE INDICATED)

The manufacturer reserves the right to make changes to the design, colour and specifications of the product shown. All images are for illustrative purposes only and some features such as grilles are optional accessories and not considered as standard equipment.

**VTAC**



# VTAC STANDARD FEATURES

## HIGH ENERGY EFFICIENCIES

Efficient design with EER as high as 12.1 and COP of 3.55 exceeding current DOE requirements.

## CAPABLE OF REPLACING OTHER BRANDS

Our VTAC units can be used as replacements for other manufacturers. Its size of 23"W x 32"H x 23"D and its slide-out chassis makes installation easy.

## COMPRESSOR AND EVAPORATOR FREEZE PROTECTION

Temperature sensors are used to detect if the compressor or evaporator is too cold and then signal to stop the operation of the unit.

## SELF-DIAGNOSTIC

Unit will perform self-diagnostics and display appropriate error code.

## RAPID HEAT MODE

When in Rapid Heat Mode electric heat will be engaged to raise the room temperature quickly. When room temperature is met, the unit will revert to standard heat pump mode.

## FACTORY TESTED

All units are thoroughly tested before shipping to ensure proper functionality.

## QUIET OPERATION

The brushless DC motor design operates quietly with a stepless configuration and stable operation.

## TWO-STAGE ELECTRIC HEATER

The electric heater is installed on the indoor air outlet to prevent insufficient air volume and internal overheating.

## FLEXIBILITY

Our vertical design saves space compared to traditional PTAC units. With its external air duct, one unit can supply conditioned air to several rooms.

## QUIET AND ENERGY EFFICIENT COMPRESSOR

Smooth operation for quiet, dependable service and high efficiency.

## SUPERIOR TEMPERATURE CONTROL

Microprocessor controls are programmed to interface with the occupant enters to maximize comfort conditions for the room occupant.

## OPERATION MEMORY RESTART AFTER POWER FAILURE

The unit setting before any power outage will be memorized and resume after power supply restarts.

## FRONT DESK CONTROL

The VTAC unit can be turned ON or OFF by front desk control before the occupant enters into the room or after leaving the room.

## DUAL FAN MOTORS

All VTAC units have two fan motors with quiet operation and maximum efficiency. Motors are permanently lubricated to reduce maintenance and totally enclosed to keep dirt and water out of the motor windings.

## CONTINUOUS FRESH AIR INTAKE

Fresh air is drawn into the VTAC unit through a manually set fresh air vent.

# VTAC ACCESSORIES

## 18 GAUGE INSULATED WALL SLEEVE

- Industry standard dimensions of 19<sup>3/4</sup>" wide x 32" high.
- The depth of the plenum is adjustable from 6" to 15" deep.

## OUTDOOR GRILLES

- Architectural grille with a minimum size of 19<sup>3/4</sup>" wide x 32" high x 1<sup>1/4</sup>" deep.

## OPTIONAL CONTROLLERS

- 24V wired thermostat or external controller.

# VTAC PRODUCT SPECIFICATIONS

## STANDARD MODELS

### HEAT PUMP WITH ELECTRIC HEATER

VTAC-HEH-[SIZE]			09-X	12-X	18-X
POWER SUPPLY		V/Ph/Hz	208-230 / 1 / 60		
COOLING	CAPACITY	BTU/H	9300/9100	11700/11500	17000/16800
	EER	BTU/w.h	12.1/12.1	11.8/11.8	11.0/11.0
	POWER INPUT	W	770/750	990/975	1545/1525
HEATING	CAPACITY	BTU/H	8500/8300	10500/10300	15700/15500
	COP	W/W	3.51/3.55	3.50/3.50	3.30/3.30
	POWER INPUT	W	710/685	880/860	1395/1375
ELECTRIC HEATER		kW	3.6		5
POWER CABLE SPECIFICATION		A	230V / 20A		230V / 30A
MAXIMUM INPUT POWER		W	917	1332	1800
MAXIMUM CURRENT		A	4.80	7.59	11.63
OPERATION CONTROL (OPTIONAL)			24V thermostat or external controller		
INDOOR FAN MOTOR	INPUT	W	130		
	SPEED (H/L)	RPM	630/530		
INDOOR AIR FLOW (H/L)		CFM	355/257	456/371	436/355
INDOOR EXTERNAL STATIC PRESSURE		in.wg	0.1		
COMPRESSOR	TYPE		Rotary On-Off		
	CAPACITOR	µF / VAC	25 / 370	30 / 370	35 / 370
OUTDOOR FAN MOTOR	INPUT	W	89		
	SPEED	RPM	1200		
REFRIGERANT	TYPE		R410A		
	CHARGE	OZ	37	34	45
RECOMMENDED OPERATION TEMPERATURE RANGE		°F	60-90		
RECOMMENDED AMBIENT TEMPERATURE RANGE			35 - 115		
NET DIMENSIONS (W x H x D)		IN	22 13/16 x 29 5/16 x 22 13/16		
PACKING DIMENSIONS (W x H x D)			26 3/16 x 32 1/4 x 26 3/16		
UNIT WEIGHT	NET	LBS	116	121	132
	SHIP		135	140	151
LOADING QUANTITY (20' / 40' / 40' HQ)		UNITS	48/102/102		

The manufacturer reserves the right to make changes to the design, colour and specifications of the product shown. All images are for illustrative purposes only and some features such as grilles are optional accessories and not considered as standard equipment.

## ESP VS AIR FLOW SPECIFICATIONS

VTAC-HEH			09-X				
ESP (IN. WATER)			0.0	0.1	0.2	0.3	0.4
INDOOR FAN	HIGH FAN	CFM	418	355	273	-	-
	LOW FAN		342	257	257	-	-
VTAC-HEH			12-X				
ESP (IN. WATER)			0.0	0.1	0.2	0.3	0.4
INDOOR FAN	HIGH FAN	CFM	515	456	386	295	-
	LOW FAN		435	371	276	-	-
VTAC-HEH			18-X				
ESP (IN. WATER)			0.0	0.1	0.2	0.3	0.4
INDOOR FAN	HIGH FAN	CFM	500	436	363	290	-
	LOW FAN		417	355	273	-	-

(ALL DIMENSIONS ARE APPROXIMATE WITHIN 1/16 OF AN INCH OF THOSE INDICATED)

The manufacturer reserves the right to make changes to the design, colour and specifications of the product shown. All images are for illustrative purposes only and some features such as grilles are optional accessories and not considered as standard equipment.

# DIMENSIONAL DATA

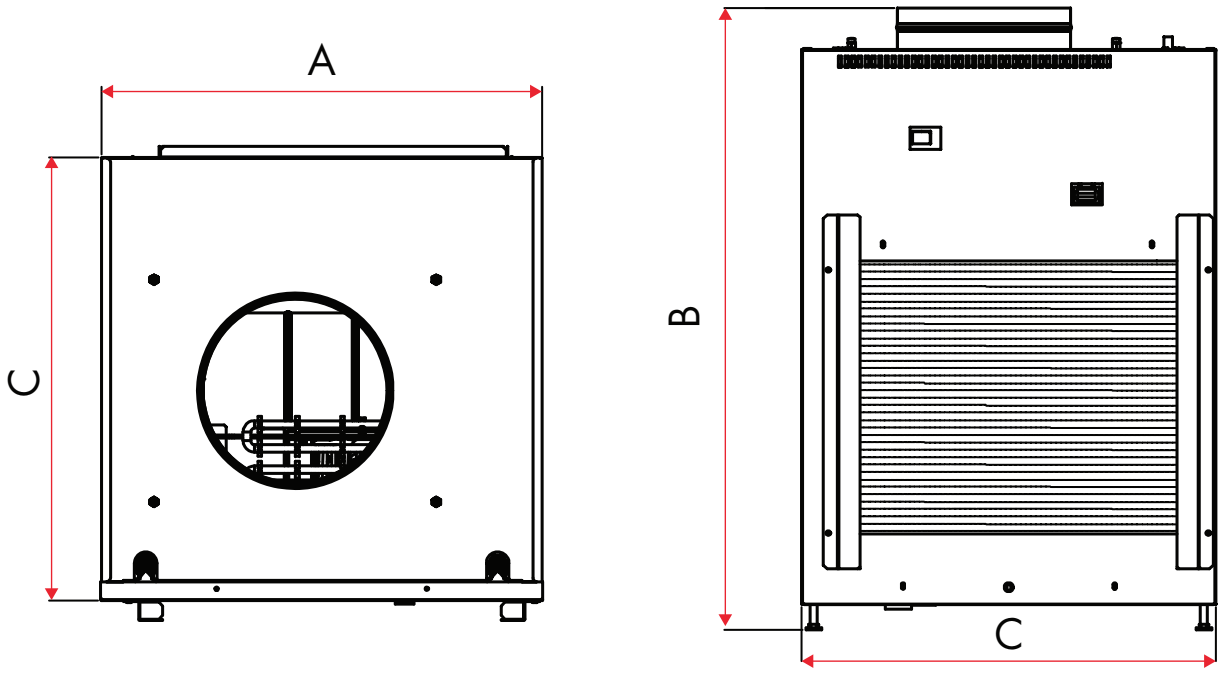

UNIT DIMENSION (INCH)		
A	B	C
23 1/8	31 1/4	23 1/8

# WALL SLEEVE DIMENSIONAL DATA

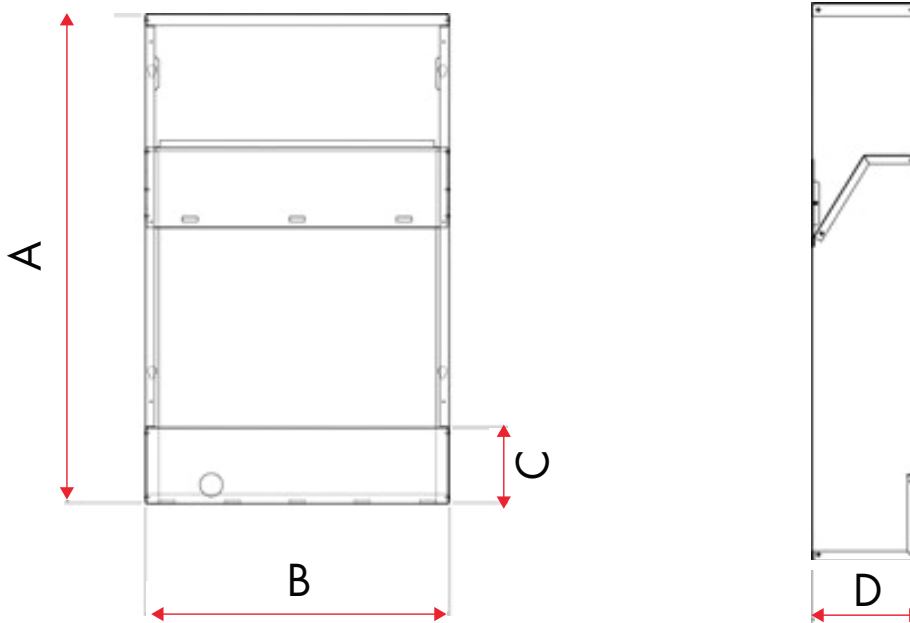

UNIT DIMENSION (INCH)						
A	B	C	D*			
23 7/8	19 3/4	5	6	8	12	15

The manufacturer reserves the right to make changes to the design, colour and specifications of the product shown. All images are for illustrative purposes only and some features such as grilles are optional accessories and not considered as standard equipment.



# ARCHITECTURAL OUTDOOR GRILLE (OPTIONAL)

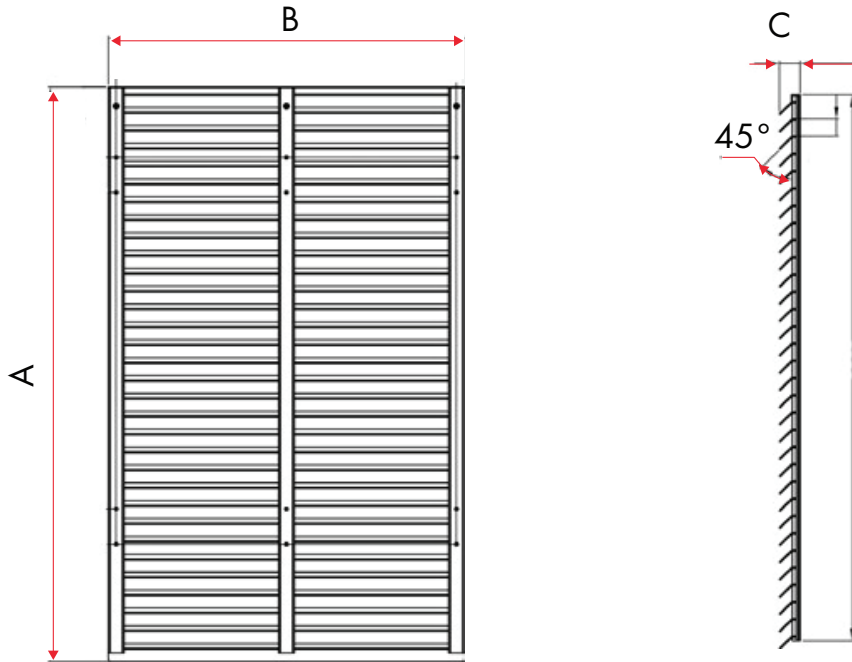

UNIT DIMENSION (INCH)		
A	B	C
32 1/8	19 7/8	1 3/16

(ALL DIMENSIONS ARE APPROXIMATE WITHIN 1/16 OF AN INCH OF THOSE INDICATED)  
 \*WALL SLEEVE OPTIONS AVAILABLE

The manufacturer reserves the right to make changes to the design, colour and specifications of the product shown. All images are for illustrative purposes only and some features such as grilles are optional accessories and not considered as standard equipment.

# VERANO<sup>®</sup>

BY MDL SOLUTIONS

COMPACT LOWER VOLTAGE FAN COILS AND HYDRONIC HEAT | MDLSOLN.COM

The data presented in this document is correct at time of publication. Illustrations may include optional accessories. Due to continuous research and development, and the desire to improve the quality of our products, MDL Solutions reserves the right to make changes regarding design and specifications without prior notice.